

# HP ProLiant DL380 Generation 4 Server Maintenance and Service Guide



May 2006 (Eighth Edition)  
Part Number 359226-008



© Copyright 2004-2006 Hewlett-Packard Development Company, L.P.

The information contained herein is subject to change without notice. The only warranties for HP products and services are set forth in the express warranty statements accompanying such products and services. Nothing herein should be construed as constituting an additional warranty. HP shall not be liable for technical or editorial errors or omissions contained herein.

Microsoft, Windows, and Windows NT are U.S. registered trademarks of Microsoft Corporation.

Intel and Xeon are trademarks or registered trademarks of Intel Corporation or its subsidiaries in the United States and other countries.

Linux is a U.S. registered trademark of Linus Torvalds.

May 2006 (Eighth Edition)

Part Number 359226-008

### Audience assumptions

This guide is for an experienced service technician. HP assumes you are qualified in the servicing of computer equipment and trained in recognizing hazards in products with hazardous energy levels and are familiar with weight and stability precautions for rack installations.

---

# Contents

Illustrated parts catalog .....	6
Customer self repair.....	6
Mechanical components (SCSI model) .....	7
System components (SCSI model) .....	8
Mechanical components (SAS model) .....	12
System components (SAS model) .....	13
Removal and replacement procedures .....	17
Introduction .....	17
Required tools.....	17
Safety considerations .....	17
Preventing electrostatic discharge .....	17
Server warnings and cautions .....	17
Preparation procedures .....	18
Extend the server from the rack.....	19
Power down the server .....	20
Remove the server from the rack .....	20
Access the product rear panel .....	21
Non-hot-plug procedures .....	22
Access panel .....	22
DVD/CD-ROM drive .....	22
DVD/CD-ROM drive ejector assembly.....	23
Diskette drive option .....	24
Front bezel .....	24
Front fan bracket .....	25
Rear fan bracket.....	26
Battery-backed write cache procedures.....	26
PCI riser cage door latch .....	30
PCI riser cage .....	31
Expansion board.....	31
Expansion slot cover .....	32
Expansion board ejector/divider .....	33
PCI slot release lever .....	34
PCI lightpipe and cover.....	35
Power converter module .....	36
Power button/LED board .....	37
DIMMs.....	38
PPM.....	39
Processor.....	39
Battery .....	41
System board.....	42
Re-entering the server serial number and product ID .....	43
Hot-plug procedures .....	44
Hot-plug SCSI hard drive .....	44
SCSI hard drive blank .....	44
Hot-plug SAS hard drive.....	45
SAS hard drive blank.....	46
Universal hot-plug tape drive.....	46
Tape drive blank .....	47
Hot-plug power supply .....	47

Power supply blank .....	48
Hot-plug fan.....	49
PCI Hot Plug expansion board .....	50
PCI Hot Plug expansion slot cover.....	52
<b>Cabling .....</b>	<b>54</b>
Cabling .....	54
SAS model cabling.....	54
SAS hard drive cabling .....	54
USB cabling.....	55
DVD/CD-ROM drive cabling.....	56
Diskette drive cabling.....	56
Power button/LED cabling .....	57
Optional PCI Hot Plug backplane cabling.....	57
RILOE II cabling.....	58
Internal power cabling .....	58
SCSI model cabling.....	58
Embedded simplex SCSI cabling .....	59
Embedded duplex SCSI cabling .....	59
PCI simplex SCSI cabling .....	60
PCI duplex SCSI cabling.....	61
Mixed duplex SCSI cabling .....	61
Installing the SCSI terminator board .....	63
Removing the SCSI terminator board.....	63
USB cabling.....	64
DVD/CD-ROM drive cabling.....	65
Diskette drive cabling.....	65
Power button/LED cabling .....	66
Optional PCI Hot Plug backplane cabling.....	66
RILOE II cabling.....	67
Internal power cabling .....	67
External storage cabling.....	68
<b>Diagnostic tools .....</b>	<b>69</b>
Troubleshooting resources .....	69
Array Diagnostic Utility .....	69
Automatic Server Recovery .....	69
HP Insight Diagnostics.....	70
Integrated Management Log .....	70
Survey Utility .....	70
HP Systems Insight Manager.....	71
Lights Out Manager technology .....	71
Option ROM Configuration for Arrays .....	71
HP ProLiant Essentials Rapid Deployment Pack .....	71
HP ROM-Based Setup Utility .....	72
SmartStart software .....	72
ROMPaq utility.....	72
System Online ROM flash component utility .....	73
<b>Component identification.....</b>	<b>74</b>
Front panel components .....	75
Front panel LEDs and buttons .....	76
Rear panel components.....	77
Rear panel LEDs and buttons.....	78
System board components.....	79

System maintenance switch.....	79
NMI switch.....	80
Chassis ID switch.....	80
DIMM slots.....	80
SCSI backplane components.....	81
SAS backplane components.....	82
System board LEDs.....	82
System LEDs and internal health LED combinations.....	83
SCSI backplane LEDs.....	85
Hot-plug SCSI hard drive LEDs.....	85
Hot-plug SCSI hard drive LED combinations.....	86
Hot-plug SAS hard drive LEDs.....	87
Hot-plug SAS hard drive LED combinations.....	87
PCI Hot Plug LED status combinations.....	88
PCI riser cage LED.....	89
Remote management connector.....	89
Internal PCI Hot Plug LEDs and button.....	90
Identifying hot-plug fans.....	90
Hot-plug fan LED.....	91
Power converter module LED.....	92
Battery-backed write cache LEDs.....	92
Battery-backed write cache LED statuses.....	93
<b>Specifications.....</b>	<b>94</b>
Server specifications.....	94
Environmental specifications.....	94
Hot-plug power supply calculations.....	95
DDR2 SDRAM DIMM specifications.....	95
1.44-MB diskette drive specifications.....	95
CD-ROM drive specifications.....	96
DVD-ROM drive specifications.....	97
Ultra320 SCSI hard drive specifications.....	98
SAS and SATA hard drive specifications.....	98
<b>Acronyms and abbreviations.....</b>	<b>99</b>
<b>Index.....</b>	<b>102</b>

---

# Illustrated parts catalog

## In this section

Customer self repair .....	6
Mechanical components (SCSI model) .....	7
System components (SCSI model) .....	8
Mechanical components (SAS model) .....	12
System components (SAS model) .....	13

## Customer self repair

### What is customer self repair?

HP's customer self-repair program offers you the fastest service under either warranty or contract. It enables HP to ship replacement parts directly to you so that you can replace them. Using this program, you can replace parts at your own convenience.

A convenient, easy-to-use program:

- An HP support specialist will diagnose and assess whether a replacement part is required to address a system problem. The specialist will also determine whether you can replace the part.
- Replacement parts are express-shipped. Most in-stock parts are shipped the very same day you contact HP. You may be required to send the defective part back to HP, unless otherwise instructed.
- Available for most HP products currently under warranty or contract. For information on the warranty service, refer to the HP website (<http://h18004.www1.hp.com/products/servers/platforms/warranty/index.html>).

For more information about HP's customer self-repair program, contact your local service provider. For the North American program, refer to the HP website (<http://www.hp.com/go/selfrepair>).

Customer replaceable parts are identified in the following tables.

# Mechanical components (SCSI model)

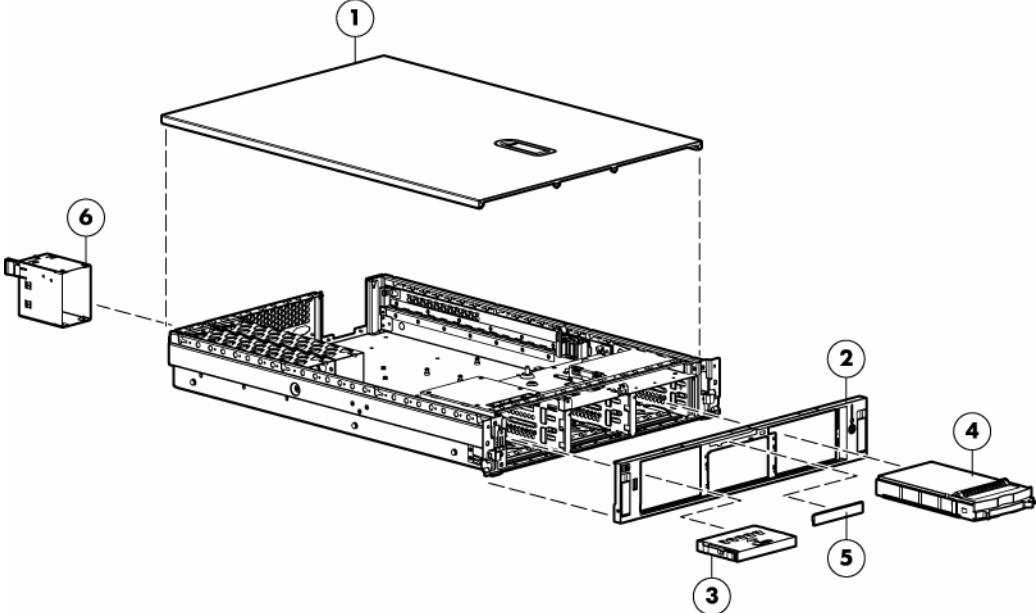

Item	Description	Original spare part number	Modified spare part number	Customer self repair
1	Access panel	359244-001	—	Yes
2	Front bezel	359245-001	—	Yes
3	Tape drive blank	367666-001	—	Yes
4	Hard drive blank	122759-001	—	Yes
5	Diskette drive slot cover (see "Plastics Kit," Item 28k)	—	—	
6	Power supply blank	359246-001	—	Yes

# System components (SCSI model)

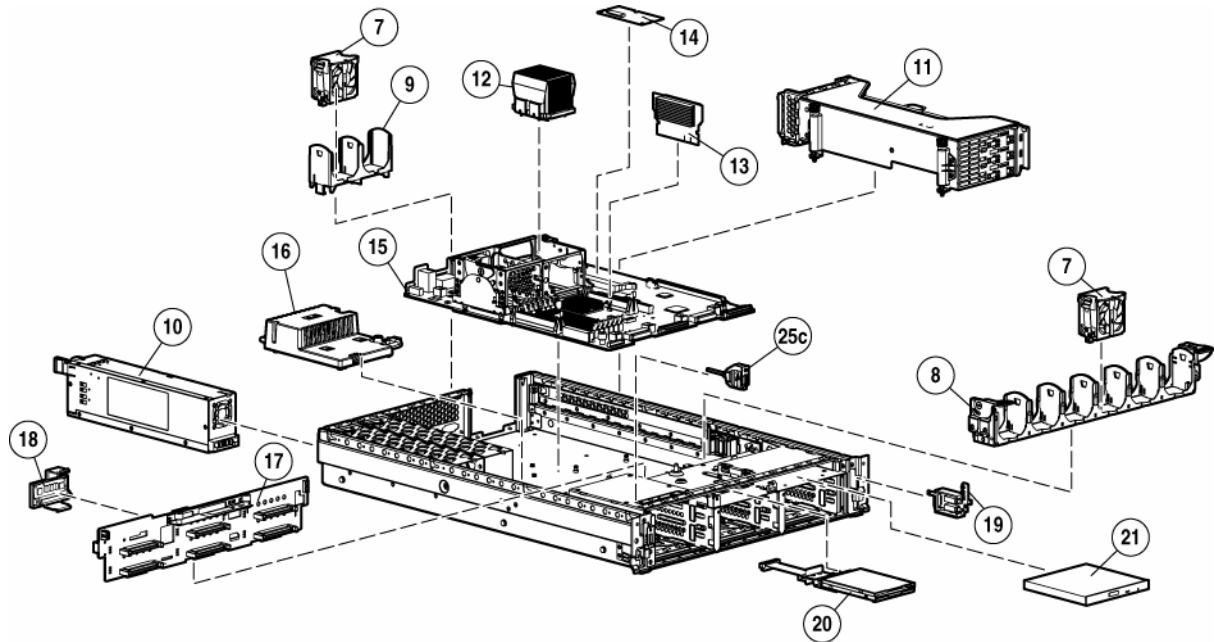

Item	Description	Original spare part number	Modified spare part number	Customer self repair
	<b>System components</b>			
7	Hot-plug fan, 60 mm	289544-001	—	Yes
8	Front fan bracket, 6 bay	371148-001	—	Yes
9	Rear fan bracket, 2 bay	289558-001	—	Yes
10	Hot-plug power supply, 400 W	338022-001‡ See requirement	406393-001	Yes
11	PCI riser cages	—	—	—
	a) PCI riser cage, with non-hot-plug PCI-X (standard)	359248-001‡ See requirement	411020-001	Yes
	b) PCI riser cage, with non-hot-plug PCI Express (optional)*	359259-001‡ See requirement	411021-001	Yes
	c) PCI riser cage, with PCI-X hot-plug (optional)*	359260-001‡ See requirement	411022-001	Yes
12	Processor assemblies	—	—	—
	a) 3.0-GHz Intel® Xeon™ 1-MB L2 cache* **	378006-001	—	Yes
	b) 3.2-GHz Intel® Xeon™ 1-MB L2 cache* **	374233-001	—	Yes
	c) 3.4-GHz Intel® Xeon™ 1-MB L2 cache* **	364757-001	—	Yes
	d) 3.6-GHz Intel® Xeon™ 1-MB L2 cache* **	364758-001	—	Yes



Item	Description	Original spare part number	Modified spare part number	Customer self repair
	e) 2.8-GHz Intel® Xeon™ 2-MB L2 cache* **	399132-001	—	Yes
	f) 3.0-GHz Intel® Xeon™ 2-MB L2 cache* **	379427-001	—	Yes
	g) 3.0-GHz Intel® Xeon™ 2-MB L2 cache LV* **	399764-001	—	Yes
	h) 3.2-GHz Intel® Xeon™ 2-MB L2 cache* **	379428-001	—	Yes
	i) 3.4-GHz Intel® Xeon™ 2-MB L2 cache* **	379429-001	—	Yes
	j) 3.6-GHz Intel® Xeon™ 2-MB L2 cache* **	379430-001	—	Yes
	k) 3.8-GHz Intel® Xeon™ 2-MB L2 cache* **	399133-001	—	Yes
	l) 2.83-GHz Intel® Xeon™ dual core, 1066-MHz FSB, 4- MB cache (for use with dual- core processor SCSI system board assembly number 012863-001 only)* **	403934-001	—	Yes
	<b>Boards</b>			
13	PPM, 12 V, 81 A	347884-001	—	Yes
14	Smart Array 6i memory module	351518-001	—	Yes
15	System board	—	—	—
	a) System board, single-core processor support, with processor cages and system battery	359251-001	—	Yes
	b) System board, dual-core processor support, SCSI, with processor cages and system battery (for use with Intel® Xeon™ dual-core processor only)*	404715-001‡ See requirement	411028-001	Yes
16	Power converter module	361667-001	—	Yes
17	SCSI backplane, 6 bay	359253-001‡ See requirement	411023-001	Yes
18	SCSI terminator	289563-001‡ See requirement	411025-001	Yes
19	Power button/LED board	366300-001‡ See requirement	411026-001	Yes
	<b>Media devices</b>			
20	Diskette drive, slimline, 1.44 MB (optional)	289550-001‡ See requirement	399311-001	Yes
21	CD-ROM drive, removable slimline, IDE, 24X	228508-001‡ See requirement	399401-001	Yes

Item	Description	Original spare part number	Modified spare part number	Customer self repair
22	DVD-ROM drive, removable slimline, 8X*	268795-001‡ See requirement	397928-001	Yes
	<b>Cables</b>			
23	SCSI cable kit*	289567-001	—	—
	a) SCSI cable, short, 68 pin	—	—	Yes
	b) SCSI cable, long, 68 pin	—	—	Yes
	c) System cable, SCSI, 50 pin	—	—	Yes
24	Signal cable kit*	228518-001	—	—
	a) Power button/LED board cable, 14 pin	—	—	Yes
	b) PCI hot-plug LED board cable	—	—	Yes
25	Miscellaneous cable kit	366063-001	—	—
	a) Diskette drive cable*	—	—	Yes
	b) CD multibay adaptor cable*	—	—	Yes
	c) USB cable and connector	—	—	Yes
	<b>Rack mounting hardware</b>			
26	2U Quick Deploy Rail System*	359254-001	—	Yes
	<b>Miscellaneous</b>			
27	Hardware kit*	228527-001	—	—
	a) Screws, T-15, flat-head	—	—	Yes
	b) Expansion slot cover	—	—	Yes
	c) Screws, 6-32	—	—	Yes
28	Plastics kit*	359720-001	—	—
	a) PCI slot release lever	—	—	Yes
	b) PCI lightpipe, rear	—	—	Yes
	c) PCI lightpipe, cover	—	—	Yes
	d) PCI riser cage door latch	—	—	Yes
	e) Thumbscrew with molded cap, PCI slot 1	—	—	Yes
	f) Standoff	—	—	Yes
	g) Plastic standoff 0.134 in	—	—	Yes
	h) Battery clip	—	—	Yes
	i) PCI card guide retainer	—	—	Yes
	j) Thumbscrew knob	—	—	Yes
	k) Diskette drive cover slot	—	—	Yes
29	AC power cord*	187335-001	—	Yes

Item	Description	Original spare part number	Modified spare part number	Customer self repair
30	DVD/CD-ROM drive ejector assembly*	371114-001	—	Yes
31	PCI expansion board ejector*	359261-001	—	Yes
32	Battery, 3.3 V, lithium*	179322-001	—	Yes
33	Country kit*	359722-001	—	Yes
34	Return kit, pack box, and cushions*	289545-001	—	Yes
35	T-15 Torx screwdriver*	199630-001	—	Yes
	<b>Memory</b>			
36	DIMM, 512 MB, registered DDR2 SDRAM*	359241-001‡ See requirement	413384-001	Yes
37	DIMM, 1 GB, registered DDR2 SDRAM*	359242-001‡ See requirement	413385-001	Yes
38	DIMM, 2 GB, registered DDR2 SDRAM*	359243-001‡ See requirement	413386-001	Yes
39	DIMM, 2 GB, registered DDR2 dual-rank SDRAM*	378021-001‡ See requirement	413387-001	Yes
40	DIMM, 4 GB, registered DDR2 SDRAM*	379984-001‡ See requirement	413388-001	Yes
	<b>Options</b>			
41	Battery-Backed Write Cache battery pack*	307132-001	—	Yes
42	Battery-Backed Write Cache battery bracket with cable*	349989-001	—	Yes
43	SCSI Ultra320 universal hot-plug hard drive	—	—	—
	a) 72.8-GB, 10,000 rpm*	289042-001‡ See requirement	404709-001	Yes
	b) 146.8-GB, 10,000 rpm*	289044-001‡ See requirement	404708-001	Yes
	c) 300-GB, 10,000 rpm*	351126-001‡ See requirement	404701-001	Yes
	d) 36.4-GB, 15,000 rpm*	289241-001‡ See requirement	404714-001	Yes
	e) 72.8-GB, 15,000 rpm*	289243-001‡ See requirement	404713-001	Yes
	f) 146.8-GB, 15,000 rpm*	347779-001‡ See requirement	404712-001	Yes

\*Not shown

\*\*Do not mix single- and dual-core processors or processors with different speeds or cache sizes.

**‡REQUIREMENT:**

**For Customers in the EU only.**

The use of the Original Spare part is regulated by RoHS legislation§.

If your unit contains a part that is labelled with the Modified Spare number, the Modified Spare must be ordered as the replacement part in the EU.

If your unit contains a part that is labelled with the Original Spare number, please order the Original Spare as the replacement part in the EU. In this case either the Original Spare or the Modified Spare may be shipped which will not affect performance or functionality of the unit.

§ Directive 2002/95/EC restricts the use of lead, mercury, cadmium, hexavalent chromium, PBBs and PBDEs in electronic products.

## Mechanical components (SAS model)

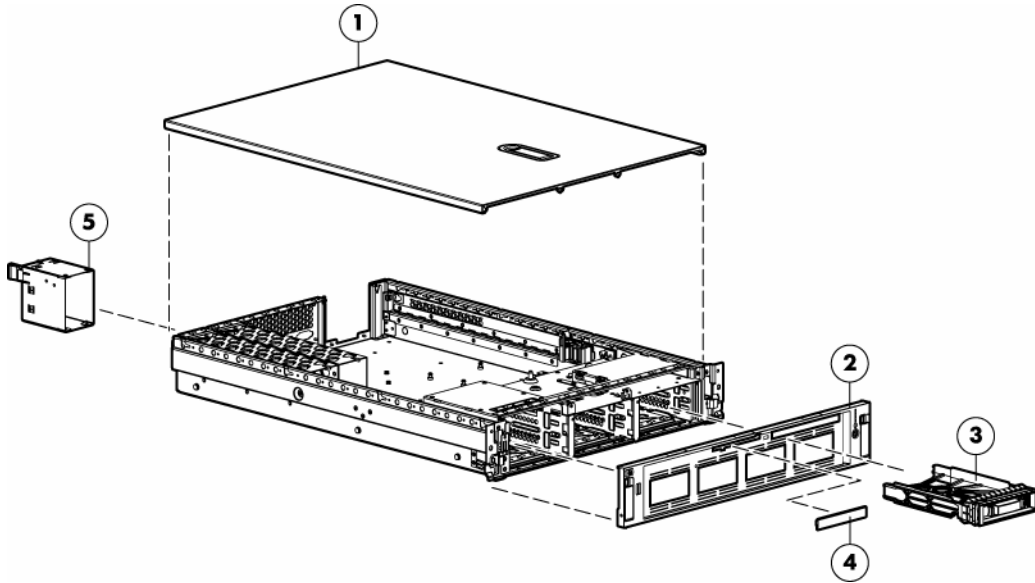

Item	Description	Original spare part number	Modified spare part number	Customer self repair
1	Access panel	359244-001	—	Yes
2	Front bezel	392614-001	—	Yes
3	Hard drive blank	392613-001	—	Yes
4	Diskette drive slot cover (see "Plastics Kit," Item 25k)	—	—	
5	Power supply blank	359246-001	—	Yes

# System components (SAS model)

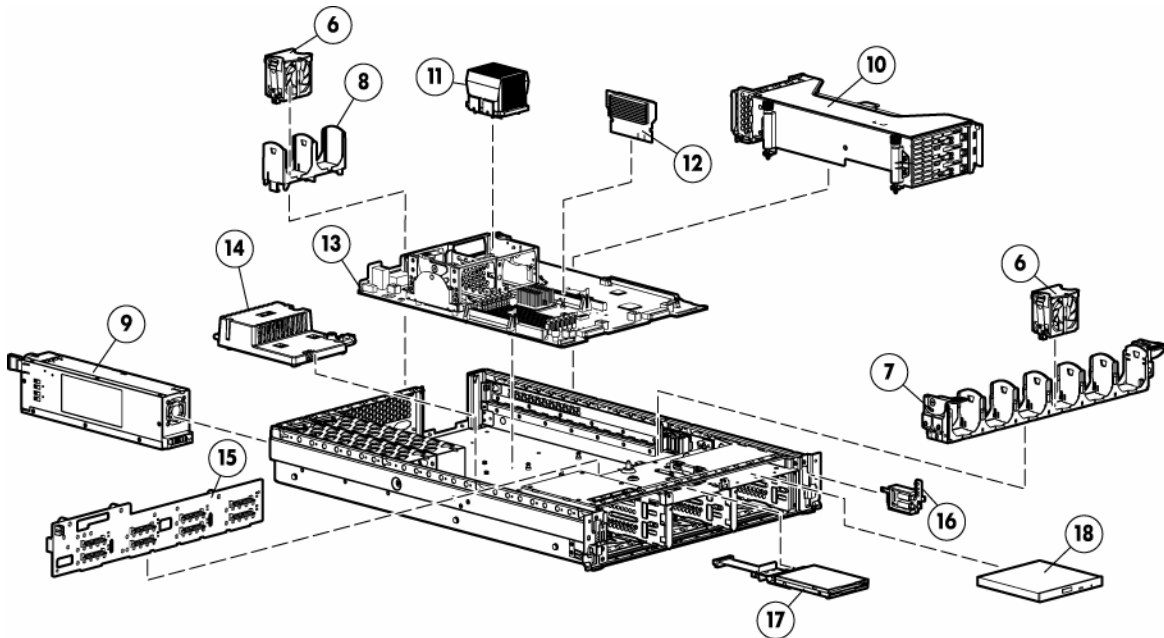

Item	Description	Original spare part number	Modified spare part number	Customer self repair
	<b>System component</b>			
6	Hot-plug fan, 60 mm	289544-001	—	Yes
7	Front fan bracket, 6 bay	371148-001	—	Yes
8	Rear fan bracket, 2 bay	289558-001	—	Yes
9	Hot-plug power supply, 400 W	338022-001‡ See requirement	406393-001	Yes
10	PCI riser cages	—	—	—
	a) PCI riser cage, with non-hot-plug PCI-X (standard)	359248-001‡ See requirement	411020-001	Yes
	b) PCI riser cage, with PCI-X hot-plug (optional)*	359260-001‡ See requirement	411022-001	Yes
11	Processor assemblies	—	—	—
	a) 3.0-GHz Intel® Xeon™ 1-MB L2 cache* **	378006-001	—	Yes
	b) 3.2-GHz Intel® Xeon™ 1-MB L2 cache* **	374233-001	—	Yes
	c) 3.4-GHz Intel® Xeon™ 1-MB L2 cache* **	364757-001	—	Yes
	d) 3.6-GHz Intel® Xeon™ 1-MB L2 cache* **	364758-001	—	Yes
	e) 2.8-GHz Intel® Xeon™ 2-MB L2 cache* **	399132-001	—	Yes
	f) 3.0-GHz Intel® Xeon™ 2-MB L2 cache* **	379427-001	—	Yes

Item	Description	Original spare part number	Modified spare part number	Customer self repair
	g) 3.0-GHz Intel® Xeon™ 2-MB L2 cache LV* **	399764-001	—	Yes
	h) 3.2-GHz Intel® Xeon™ 2-MB L2 cache* **	379428-001	—	Yes
	i) 3.4-GHz Intel® Xeon™ 2-MB L2 cache* **	379429-001	—	Yes
	j) 3.6-GHz Intel® Xeon™ 2-MB L2 cache* **	379430-001	—	Yes
	k) 3.8-GHz Intel® Xeon™ 2-MB L2 cache* **	399133-001	—	Yes
	l) 2.83-GHz Intel® Xeon™ dual-core, 1066-MHz FSB, 4-MB cache (for use with dual-core processor SAS system board assembly number 012977-001 only)* **	403934-001	—	Yes
	<b>Boards</b>			
12	PPM, 12 V, 81 A	347884-001	—	Yes
13	System board	—	—	—
	a) System board, with processor cages and system battery	392609-001	—	Yes
	b) System board, dual-core processor support, SAS, with processor cages and system battery (for use with Intel® Xeon™ dual-core processor only)*	409160-001‡ See requirement	411030-001	Yes
14	Power converter module	392611-001	—	Yes
15	SAS backplane, 8 bay	392610-001‡ See requirement	411024-001	Yes
16	Power button/LED board	366300-001‡ See requirement	411026-001	Yes
	<b>Media devices</b>			
17	Diskette drive, slimline, 1.44 MB (optional)	289550-001‡ See requirement	399311-001	Yes
18	CD-ROM drive, removable slimline, IDE, 24X	228508-001‡ See requirement	399401-001	Yes
19	DVD-ROM drive, removable slimline, 8X*	268795-001‡ See requirement	397928-001	Yes
	<b>Cables</b>			
20	SAS options cable kit*	392612-001	—	—
	a) Drive cage cable	—	—	Yes
	b) CD multi-bay cable	—	—	Yes
21	SAS option cable*	389952-001	—	Yes

Item	Description	Original spare part number	Modified spare part number	Customer self repair
22	Signal cable kit*	228518-001	—	—
	a) Power button/LED board cable, 14 pin	—	—	Yes
	b) PCI hot-plug LED board cable	—	—	Yes
	Miscellaneous cable kit*	366063-001	—	—
	a) Diskette drive cable*	—	—	Yes
	b) CD multibay adaptor cable*	—	—	Yes
	c) USB cable and connector*	—	—	Yes
	<b>Rack mounting hardware</b>			
23	2U Quick Deploy Rail System*	359254-001	—	Yes
	<b>Miscellaneous</b>			
24	Hardware kit*	228527-001	—	—
	a) Screws, T-15, flat-head	—	—	Yes
	b) Expansion slot cover	—	—	Yes
	c) Screws, 6-32	—	—	Yes
25	Plastics kit*	359720-001	—	—
	a) PCI slot release lever	—	—	Yes
	b) PCI lightpipe, rear	—	—	Yes
	c) PCI lightpipe, cover	—	—	Yes
	d) PCI riser cage door latch	—	—	Yes
	e) Thumbscrew with molded cap, PCI slot 1	—	—	Yes
	f) Standoff	—	—	Yes
	g) Plastic standoff 0.134 in	—	—	Yes
	h) Battery clip	—	—	Yes
	i) PCI card guide retainer	—	—	Yes
	j) Thumbscrew knob	—	—	Yes
	k) Diskette drive slot cover	—	—	Yes
26	AC power cord*	187335-001	—	Yes
27	DVD/CD-ROM drive ejector assembly*	371114-001	—	Yes
28	PCI expansion board ejector*	359261-001	—	Yes
29	Battery, 3.3 V, lithium*	179322-001	—	Yes
30	Country kit*	359722-001	—	Yes

Item	Description	Original spare part number	Modified spare part number	Customer self repair
31	Return kit, pack box, and cushions*	289545-001	—	Yes
32	T-15 Torx screwdriver*	199630-001	—	Yes
	<b>Memory</b>			
33	DIMM, 512 MB, registered DDR2 SDRAM*	359241-001‡ See requirement	413384-001	Yes
34	DIMM, 1 GB, registered DDR2 SDRAM*	359242-001‡ See requirement	413385-001	Yes
35	DIMM, 2 GB, registered DDR2 SDRAM*	359243-001‡ See requirement	413386-001	Yes
36	DIMM, 2 GB, registered DDR2 dual-rank SDRAM*	378021-001‡ See requirement	413387-001	Yes
37	DIMM, 4 GB, registered DDR2 SDRAM*	379984-001‡ See requirement	413388-001	Yes
	<b>Options</b>			
38	Smart Array P600 Controller*	370855-001	—	Yes
39	SAS array cache board, 256-MB (with battery)*	309522-001	—	Yes
40	SAS array cache board, 512-MB (with battery)*	378202-001	—	Yes
41	SAS hot-plug hard drive	—	—	—
	a) 36-GB, 10,000 rpm, 2.5 in*	376596-001	—	Yes
	b) 72-GB, 10,000 rpm, 2.5 in*	376597-001	—	Yes
42	60-GB, 5,4000 rpm, SFF SATA hard drive, 1 yr wty*	382264-001	—	Yes

\*Not shown

\*\*Do not mix single- and dual-core processors or processors with different speeds or cache sizes.

**‡REQUIREMENT:**

**For Customers in the EU only.**

The use of the Original Spare part is regulated by RoHS legislation§.

If your unit contains a part that is labelled with the Modified Spare number, the Modified Spare must be ordered as the replacement part in the EU.

If your unit contains a part that is labelled with the Original Spare number, please order the Original Spare as the replacement part in the EU. In this case either the Original Spare or the Modified Spare may be shipped which will not affect performance or functionality of the unit.

§Directive 2002/95/EC restricts the use of lead, mercury, cadmium, hexavalent chromium, PBBs and PBDEs in electronic products.



---

# Removal and replacement procedures

## In this section

Introduction .....	17
Required tools.....	17
Safety considerations.....	17
Preparation procedures.....	18
Non-hot-plug procedures.....	22
Hot-plug procedures .....	44

## Introduction

The SCSI model and SAS model servers look different. The procedures in this section apply to either server model unless otherwise noted.

## Required tools

You need the following items for some procedures:

- T-15 Torx screwdriver (provided inside the server)
- HP Insight Diagnostics software ("[HP Insight Diagnostics](#)" on page 70)

## Safety considerations

Before performing service procedures, review all the safety information.

## Preventing electrostatic discharge

To prevent damaging the system, be aware of the precautions you need to follow when setting up the system or handling parts. A discharge of static electricity from a finger or other conductor may damage system boards or other static-sensitive devices. This type of damage may reduce the life expectancy of the device.

To prevent electrostatic damage:

- Avoid hand contact by transporting and storing products in static-safe containers.
- Keep electrostatic-sensitive parts in their containers until they arrive at static-free workstations.
- Place parts on a grounded surface before removing them from their containers.
- Avoid touching pins, leads, or circuitry.
- Always be properly grounded when touching a static-sensitive component or assembly.

## Server warnings and cautions

Before installing a server, be sure that you understand the following warnings and cautions.

- ⚠ WARNING:** To reduce the risk of electric shock or damage to the equipment:
- **Do not disable the power cord grounding plug. The grounding plug is an important safety feature.**
  - **Plug the power cord into a grounded (earthed) electrical outlet that is easily accessible at all times.**
  - **Unplug the power cord from the power supply to disconnect power to the equipment.**
  - **Do not route the power cord where it can be walked on or pinched by items placed against it. Pay particular attention to the plug, electrical outlet, and the point where the cord extends from the server.**
- ⚠ WARNING:** To reduce the risk of personal injury from hot surfaces, allow the drives and the internal system components to cool before touching them.
- ⚠ CAUTION:** Do not operate the server for long periods with the access panel open or removed. Operating the server in this manner results in improper airflow and improper cooling that can lead to thermal damage.

## Preparation procedures

To access some components and perform certain service procedures, you must perform one or more of the following procedures:

- Extend the server from the rack (on page 19).  
If you are performing service procedures in an HP, Compaq branded, telco, or third-party rack cabinet, you can use the locking feature of the rack rails to support the server and gain access to internal components.  
For more information about telco rack solutions, refer to the RackSolutions.com website (<http://www.racksolutions.com/hp>).
- Power down the server (on page 20).  
If you must remove a server from a rack or a non-hot-plug component from a server, power down the server.
- Remove the server from the rack (on page 20).  
If the rack environment, cabling configuration, or the server location in the rack creates awkward conditions, remove the server from the rack.

## Extend the server from the rack

1. Pull down the quick release levers on each side of the server to release the server from the rack.

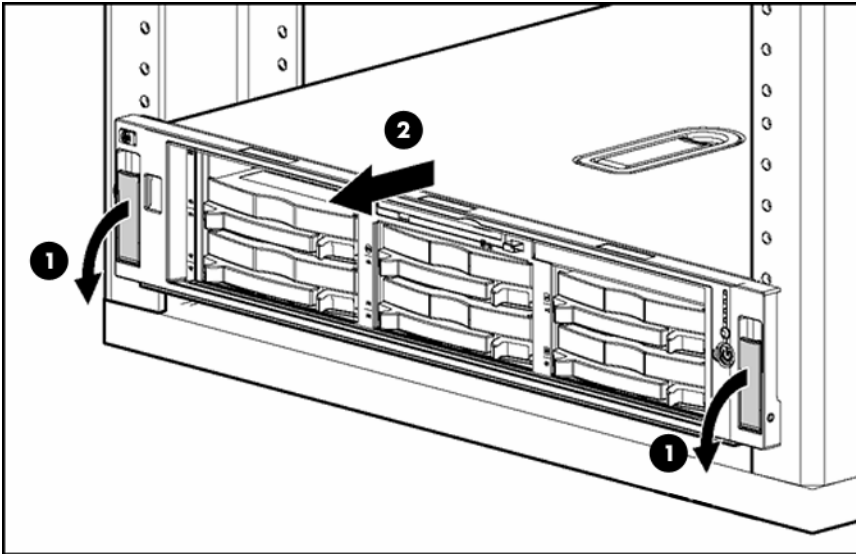

2. Extend the server on the rack rails until the server rail-release latches engage.

**⚠ WARNING:** To reduce the risk of personal injury or equipment damage, be sure that the rack is adequately stabilized before extending a component from the rack.

**⚠ WARNING:** To reduce the risk of personal injury, be careful when pressing the server rail-release latches and sliding the server into the rack. The sliding rails could pinch your fingers.

3. After performing the installation or maintenance procedure, slide the server back into the rack:
  - a. Press the server rail-release latches and slide the server fully into rack.

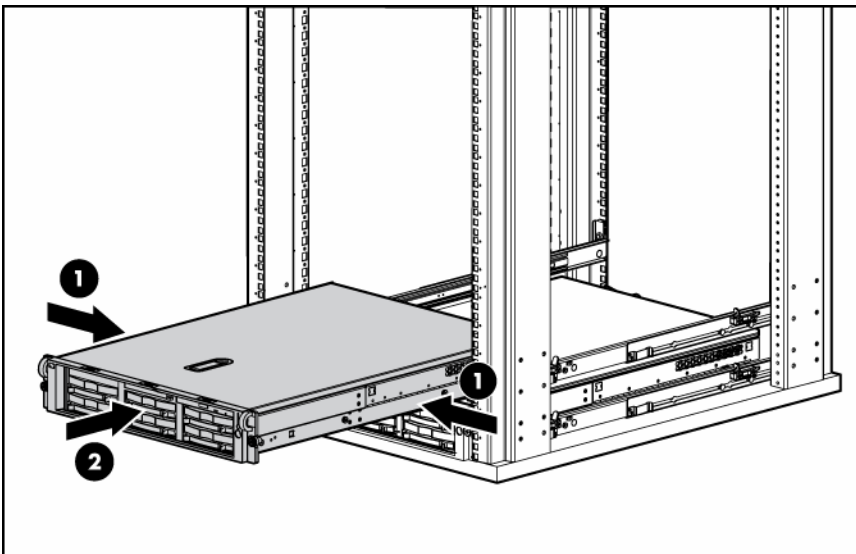

- b. Press the server firmly into the rack to secure it in place.

## Power down the server

**⚠ WARNING:** To reduce the risk of personal injury, electric shock, or damage to the equipment, remove the power cord to remove power from the server. The front panel Power On/Standby button does not completely shut off system power. Portions of the power supply and some internal circuitry remain active until AC power is removed.

**📌 IMPORTANT:** If installing a hot-plug device, it is not necessary to power down the server.

1. Back up the server data.
2. Shut down the operating system as directed by the operating system documentation.
3. If the server is installed in a rack, press the UID LED button on the front panel (1). Blue LEDs illuminate on the front and rear panels of the server.
4. Press the Power On/Standby button to place the server in standby mode (2). When the server activates standby power mode, the system power LED changes to amber.

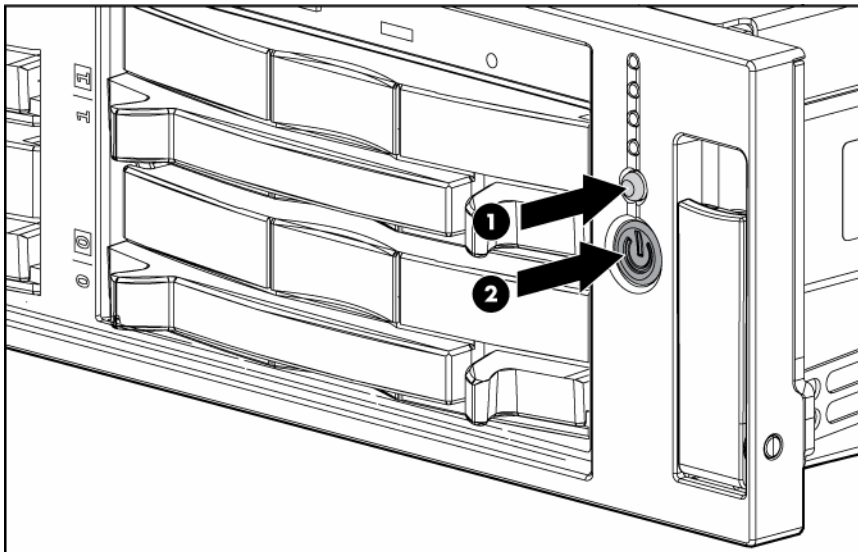

5. If the server is installed in a rack, locate the server by identifying the illuminated rear UID LED button.
  6. Disconnect the power cords.
- The system is now without power.

## Remove the server from the rack

To remove the server from an HP, Compaq branded, telco, or third-party rack:

1. Power down the server (on page 20).
2. Extend the server from the rack (on page 19).
3. Disconnect the cabling and remove the server from the rack. For more information, refer to the documentation that ships with the rack mounting option.
4. Place the server on a sturdy, level surface.

## Access the product rear panel

### Cable management arm with left-hand swing

To access the server rear panel, open the cable management arm.

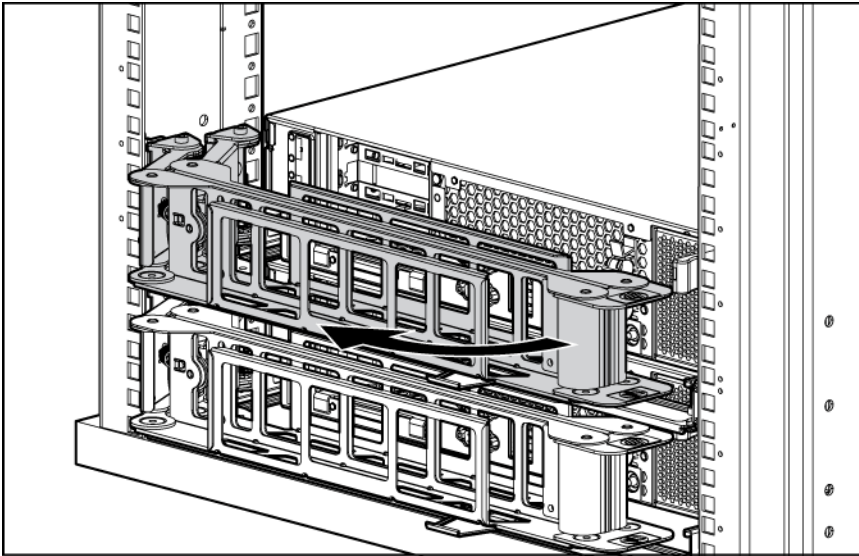

To close the cable management arm, reverse this procedure.

### Cable management arm with right-hand swing



**NOTE:** To access some components, you may need to remove the cable management arm.

To access the product rear panel components, open the cable management arm.

1. Power down the server (on page 20).
2. Swing open the cable management arm.
3. Remove the cables from the cable trough.
4. Remove the cable management arm.

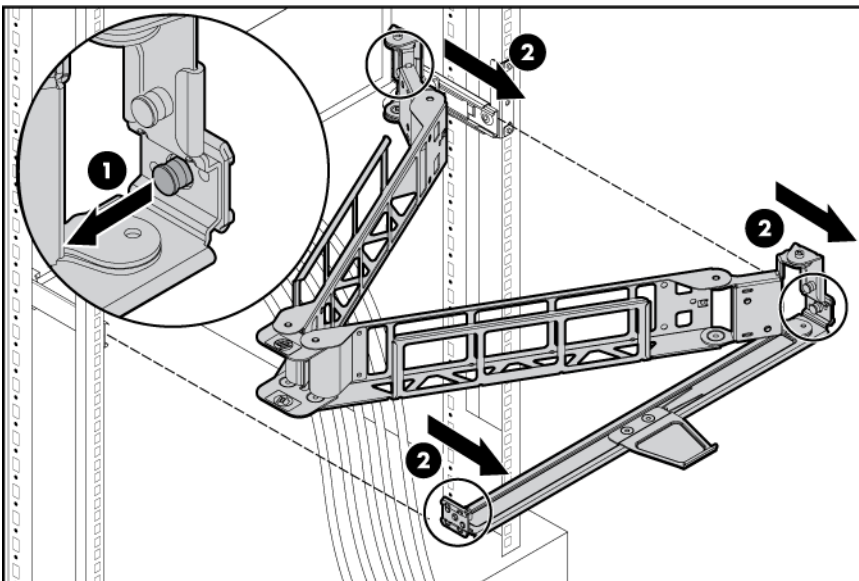

To close the cable management arm, reverse this procedure.

## Non-hot-plug procedures

### Access panel

**⚠ WARNING:** To reduce the risk of personal injury from hot surfaces, allow the drives and the internal system components to cool before touching them.

**⚠ CAUTION:** Do not operate the server for long periods with the access panel open or removed. Operating the server in this manner results in improper airflow and improper cooling that can lead to thermal damage.

To remove the component:

1. Power down the server if performing a non-hot-plug installation or maintenance procedure ("[Power down the server](#)" on page 20).
2. Extend the server from the rack, if applicable ("[Extend the server from the rack](#)" on page 19).
3. Lift up on the hood latch handle and remove the access panel.

To replace the component, reverse the removal procedure.

### DVD/CD-ROM drive

To remove the component:

**⚠ CAUTION:** To prevent improper cooling and thermal damage, do not operate the server unless all bays are populated with either a component or a blank.

1. Power down the server (on page 20).

**📌 IMPORTANT:** The ejector button is recessed to prevent accidental ejection; it may be helpful to use a pen or similar shaped object to access the button.

2. Remove the drive.

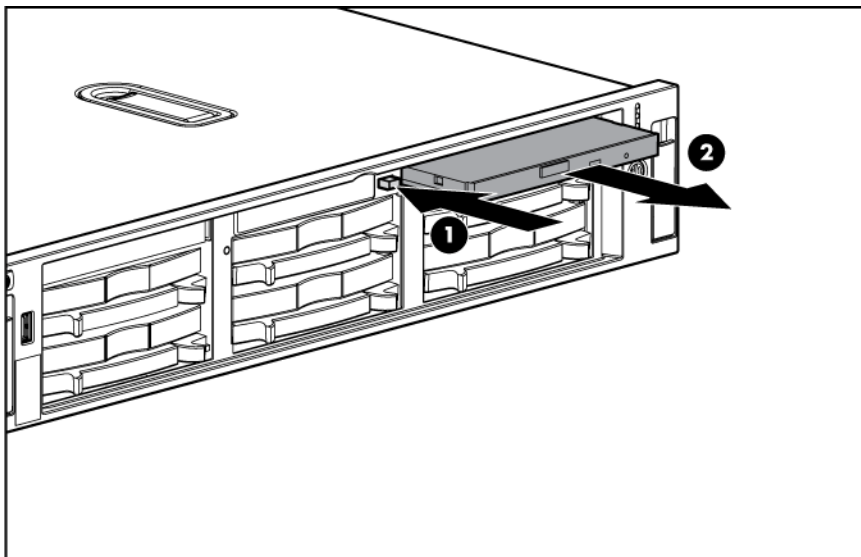

To replace the drive, slide the drive into the bay until the drive is fully seated.

## DVD/CD-ROM drive ejector assembly

To remove the component:

1. Power down the server (on page 20).
2. Extend or remove the server from the rack ("Extend the server from the rack" on page 19, "Remove the server from the rack" on page 20).
3. Remove the access panel ("Access panel" on page 22).
4. Remove the DVD/CD-ROM drive, if installed ("DVD/CD-ROM drive" on page 22).
5. Remove the diskette drive ("Diskette drive option" on page 24).
6. Remove the ejector lever.

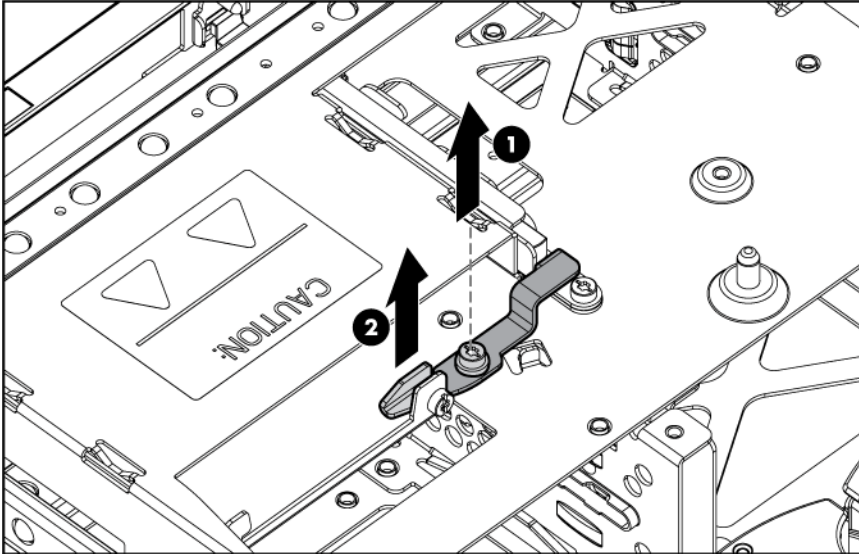

7. Press and hold the ejector button.
8. Remove the ejector assembly.

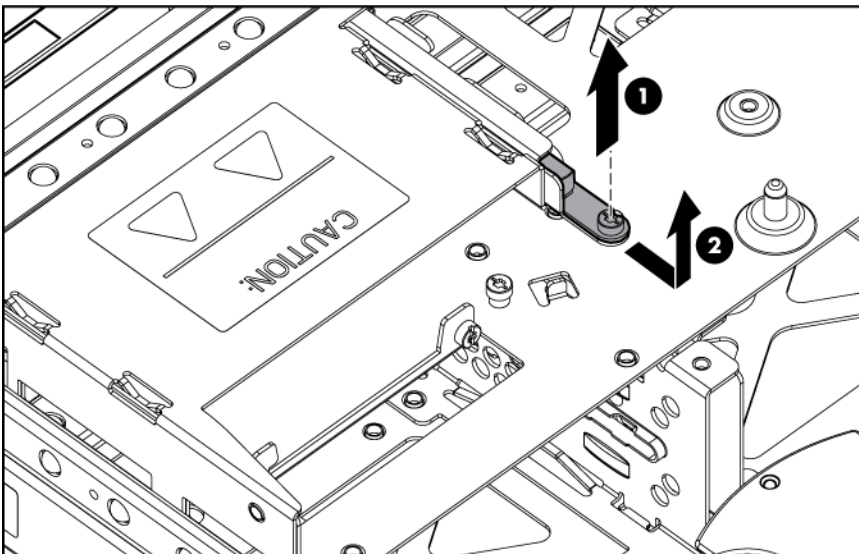

To replace the component, reverse the removal procedure.



## Diskette drive option

To remove the component:

**△ CAUTION:** To prevent improper cooling and thermal damage, do not operate the server unless all bays are populated with either a component or a blank.

1. Power down the server (on page 20).
2. Extend or remove the server from the rack ("Extend the server from the rack" on page 19, "Remove the server from the rack" on page 20).
3. Remove the access panel ("Access panel" on page 22).
4. Remove the diskette drive.

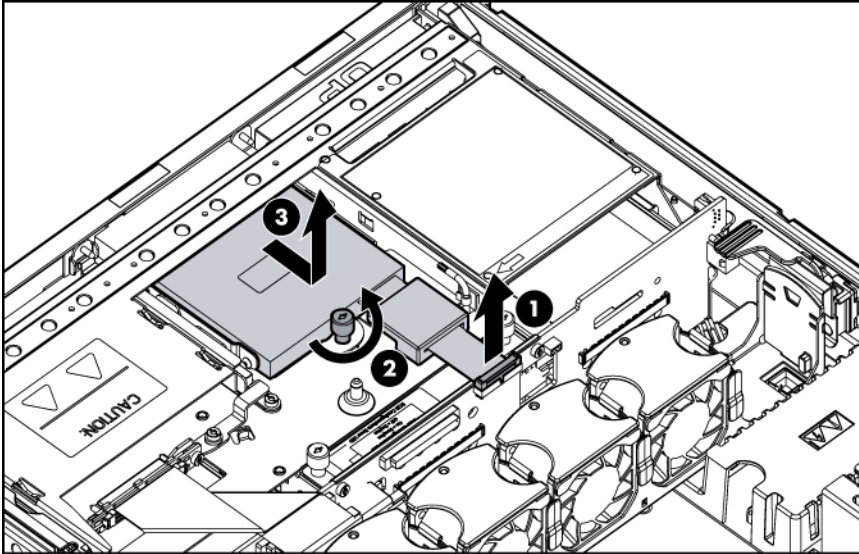

To replace the component, reverse the removal procedure.

## Front bezel

To remove the component:

1. Power down the server (on page 20).
2. Extend or remove the server from the rack ("Extend the server from the rack" on page 19, "Remove the server from the rack" on page 20).



3. Remove the two screws and detach the front bezel.

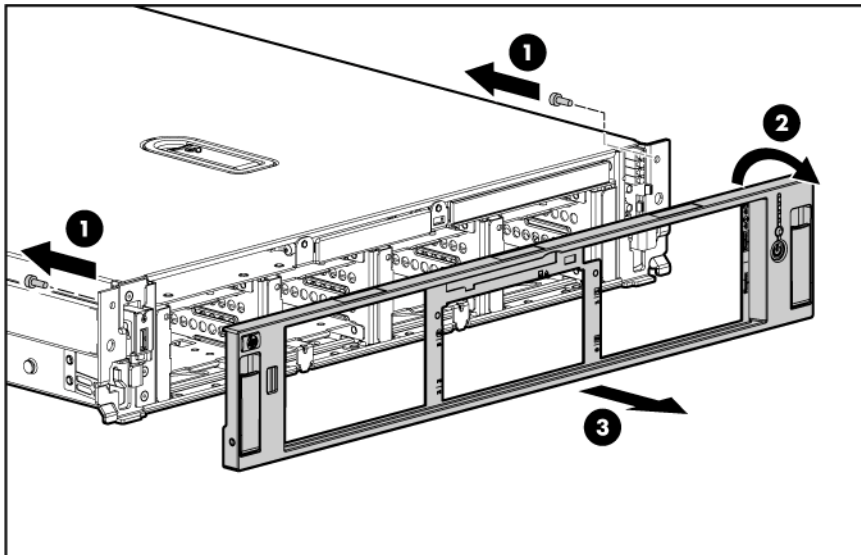

To replace the component, reverse the removal procedure.

## Front fan bracket

To remove the component:

1. Power down the server (on page 20).
2. Extend or remove the server from the rack ("Extend the server from the rack" on page 19, "Remove the server from the rack" on page 20).
3. Remove the access panel ("Access panel" on page 22).
4. Remove the front fan bracket.

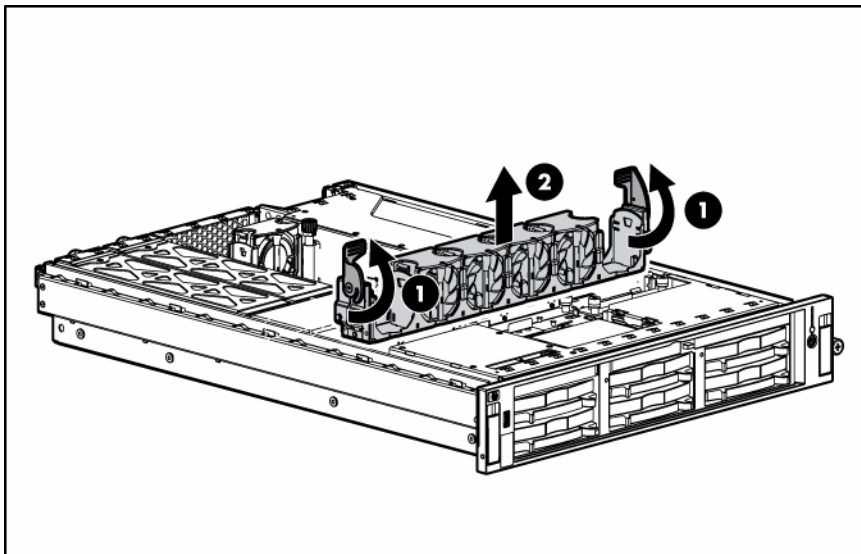

5. Remove all hot-plug fans from the front fan bracket ("Hot-plug fan" on page 49).

To replace the front fan bracket, reverse the removal steps and press down on the top of each fan to be sure it is seated properly.

## Rear fan bracket

To remove the component:

1. Power down the server (on page 20).
2. Extend or remove the server from the rack ("Extend the server from the rack" on page 19, "Remove the server from the rack" on page 20).
3. Remove the access panel ("Access panel" on page 22).

**CAUTION:** To prevent damage to the server or expansion boards, power down the server and remove all AC power cords before removing or installing the PCI riser cage.

4. Remove the PCI riser cage.
5. Remove the front fan bracket ("Front fan bracket" on page 25).

**IMPORTANT:** For this procedure, you do not need to remove the hot-plug fans from the front fan bracket. When reinstalling the front fan bracket, press the top of each fan to be sure it seats securely.

6. Remove the hot-plug fans from the rear fan bracket ("Hot-plug fan" on page 49).
7. Remove the system board.

**NOTE:** When removing the system board, you may leave the DIMMs, the processors, the PPMs, the Smart Array 6i memory module, and the system battery on the system board, unless you are replacing them as failed items.

8. Remove the rear fan bracket.

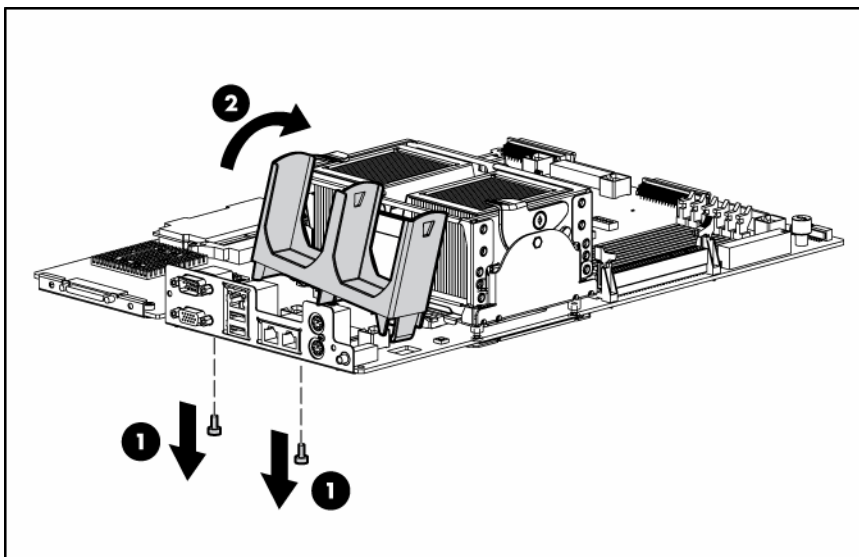

To replace the component, reverse the removal procedure.

## Battery-backed write cache procedures

**NOTE:** This feature applies only to SCSI models.

Two types of procedures are provided for the BBWC option:

- Removal and replacement of failed components:
  - Removing the Smart Array 6i cache module
  - Removing the BBWC battery pack

- Recovery of cached data from a failed server ("[Recovering data from the battery-backed write cache](#)" on page 29)

**CAUTION:** Do not detach the cable that connects the battery pack to the cache module. Detaching the cable causes any unsaved data in the cache module to be lost.

## Smart Array 6i cache module

To remove the component:

1. Power down the server (on page 20).
2. Extend or remove the server from the rack ("[Extend the server from the rack](#)" on page 19, "[Remove the server from the rack](#)" on page 20).
3. Remove the access panel ("[Access panel](#)" on page 22).

**CAUTION:** To prevent damage to the server or expansion boards, power down the server and remove all AC power cords before removing or installing the PCI riser cage.

4. Remove the PCI riser cage.

**CAUTION:** To prevent a server malfunction or damage to the equipment, do not add or remove the battery pack while an array capacity expansion, RAID level migration, or stripe size migration is in progress.

**CAUTION:** After the server is powered down, wait 15 seconds and then check the amber LED before unplugging the cable from the cache module. If the amber LED blinks after 15 seconds, do not remove the cable from the cache module. The cache module is backing up data, and data is lost if the cable is detached.

5. Remove the cable from the plastic retainer.

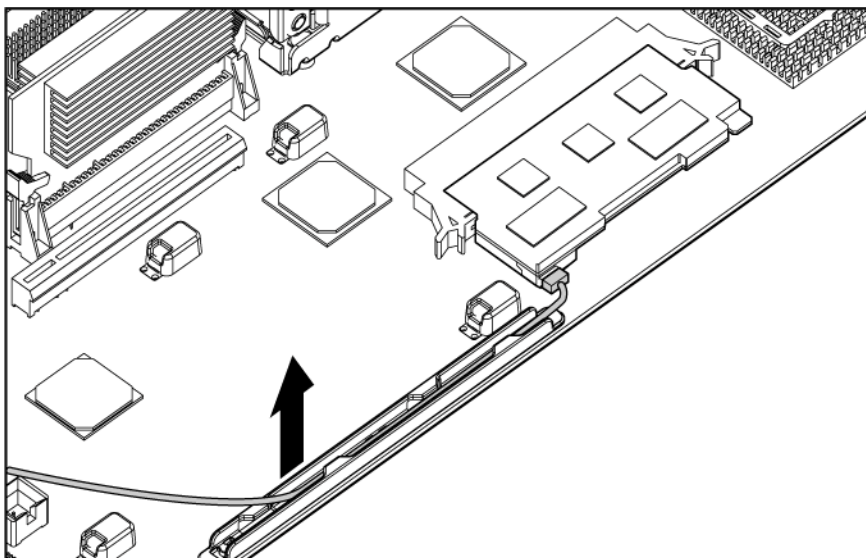

6. Remove the Smart Array 6i cache module.

7. Disconnect the cable.

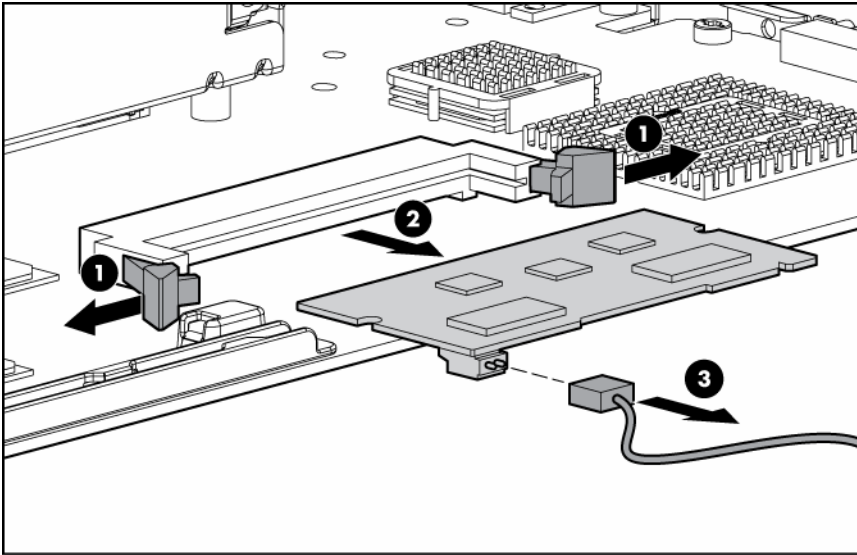

To replace the component, reverse the removal procedure.

**CAUTION:** To prevent damage to the cache module during installation, be sure the cache module is fully inserted before pressing down.

### Battery-backed write cache battery pack

To remove the component:

1. Power down the server (on page 20).
2. Extend or remove the server from the rack ("[Extend the server from the rack](#)" on page 19, "[Remove the server from the rack](#)" on page 20).
3. Remove the access panel ("[Access panel](#)" on page 22).

**CAUTION:** To prevent a server malfunction or damage to the equipment, do not add or remove the battery pack while an array capacity expansion, RAID level migration, or stripe size migration is in progress.

**CAUTION:** After the server is powered down, wait 15 seconds and then check the amber LED before unplugging the cable from the cache module. If the amber LED blinks after 15 seconds, do not remove the cable from the cache module. The cache module is backing up data, and data is lost if the cable is detached.

4. Remove the front fan bracket ("[Front fan bracket](#)" on page 25).
5. Remove the Smart Array 6i cache module.

6. Remove the BBWC enabler, also known as the battery pack.

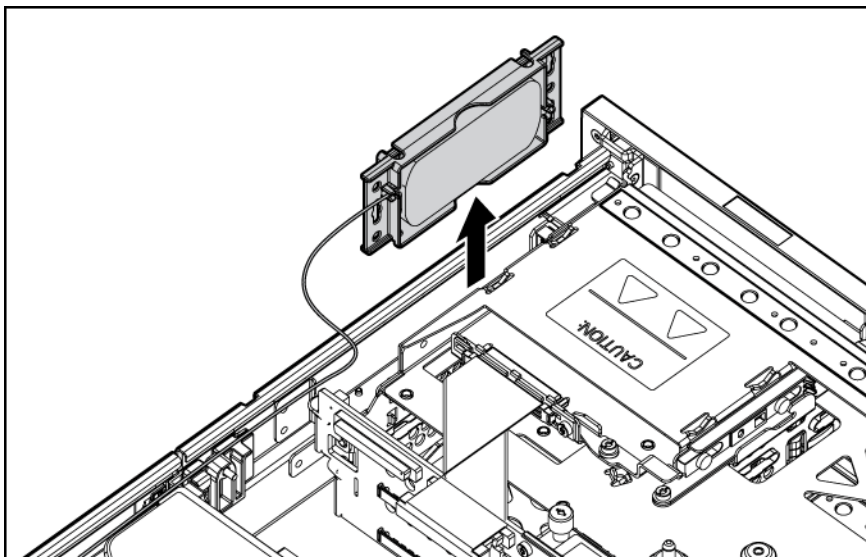

To replace the component, reverse the removal procedure.

**IMPORTANT:** The battery pack might have a low charge when installed. In this case, a POST error message is displayed when the server is powered up, indicating that the battery pack is temporarily disabled. No action is necessary on your part. The internal circuitry automatically recharges the batteries and enables the battery pack. This process might take up to four hours. During this time, the cache module functions properly, but without the performance advantage of the battery pack.

**NOTE:** The data protection and the time limit also apply if a power outage occurs. When power is restored to the system, an initialization process writes the preserved data to the hard drives.

## Recovering data from the battery-backed write cache

If the server fails, you can recover any data temporarily trapped in the BBWC by using the following procedure.

**CAUTION:** Before starting this procedure, read the information about protecting against electrostatic discharge ("[Preventing electrostatic discharge](#)" on page 17).

1. Perform one of the following:
  - Set up a recovery server station using an identical server model. Do not install any internal drives or BBWC in this server. (This is the preferred option.)
  - Find a server that has enough empty drive bays to accommodate all the drives from the failed server and that meets all the other requirements for drive and array migration.
2. Power down the failed server ("[Power down the server](#)" on page 20). If any data is trapped in the cache module, an amber LED on the module blinks every 15 seconds.

**CAUTION:** Do not detach the cable that connects the battery pack to the cache module. Detaching the cable causes any unsaved data in the cache module to be lost.

3. Transfer the hard drives from the failed server to the recovery server station.
4. Remove the BBWC [cache module and battery pack] from the failed server.
5. Perform one of the following:
  - Install the BBWC into an empty BBWC DIMM socket on the system board of the recovery server.

- Install the BBWC into an empty BBWC DIMM socket on any Smart Array 641 or 642 Controller in the recovery server.
6. Power up the recovery server. A 1759 POST message is displayed, stating that valid data was flushed from the cache. This data is now stored on the drives in the recovery server. You can now transfer the drives (and controller, if one was used) to another server.

## PCI riser cage door latch

To remove the component:

1. Extend or remove the server from the rack ("Extend the server from the rack" on page 19, "Remove the server from the rack" on page 20).
2. Remove the access panel ("Access panel" on page 22).
3. Open the PCI riser cage door.

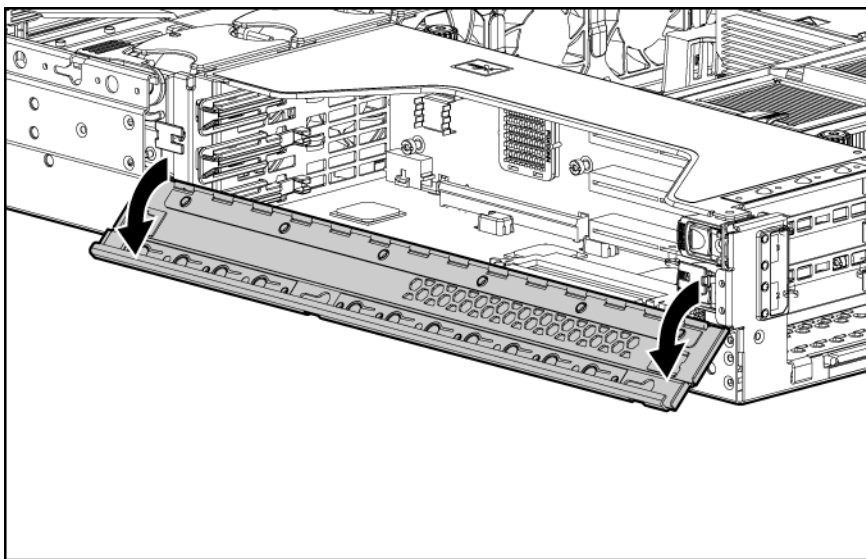

4. Remove the PCI riser cage door latch.

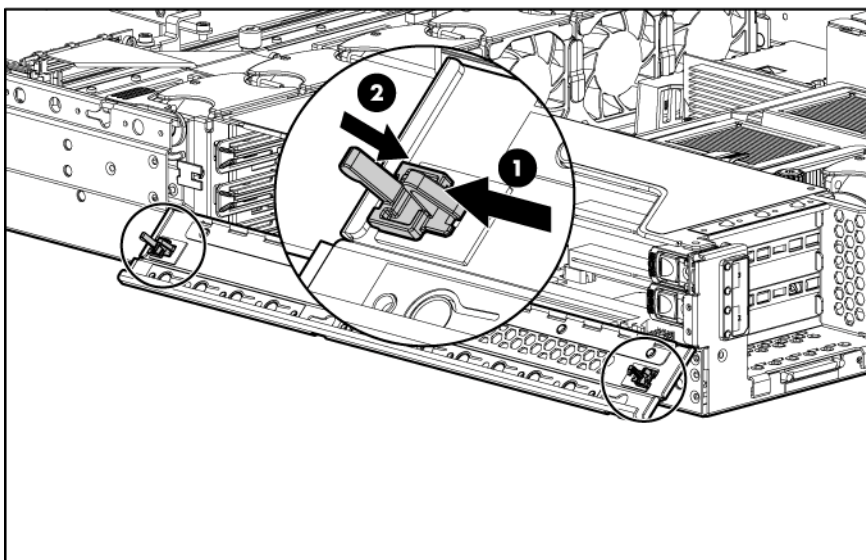

To replace the component, reverse the removal procedure.



## PCI riser cage

To remove the component:

1. Power down the server (on page 20).
2. Extend the server from the rack, if applicable ("[Extend the server from the rack](#)" on page 19).
3. Remove the access panel ("[Access panel](#)" on page 22).

**△ CAUTION:** To prevent damage to the server or expansion boards, power down the server and remove all AC power cords before removing or installing the PCI riser cage.

4. Disconnect any internal or external cables connected to any existing expansion boards.
5. Lift the PCI riser cage thumbscrews and turn them counter-clockwise.
6. Remove the PCI riser cage.

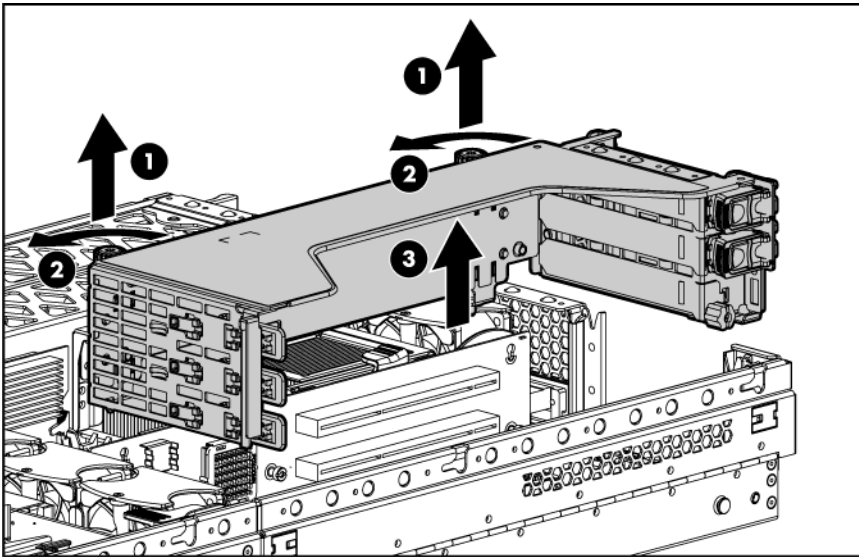

To replace the component, reverse the removal procedure.

## Expansion board

To remove the component:

1. Power down the server (on page 20).
2. Extend or remove the server from the rack ("[Extend the server from the rack](#)" on page 19, "[Remove the server from the rack](#)" on page 20).
3. Remove the access panel ("[Access panel](#)" on page 22).

**△ CAUTION:** To prevent damage to the server or expansion boards, power down the server and remove all AC power cords before removing or installing the PCI riser cage.

4. Disconnect any cables connecting the expansion board to the PCI riser cage.
5. Remove the PCI riser cage.

6. Unlock the PCI retaining clip.

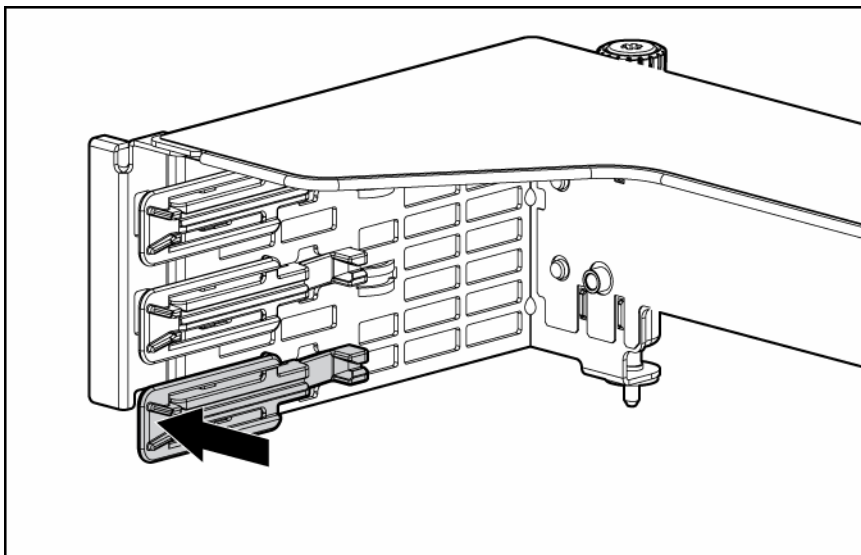

7. Remove the expansion board.

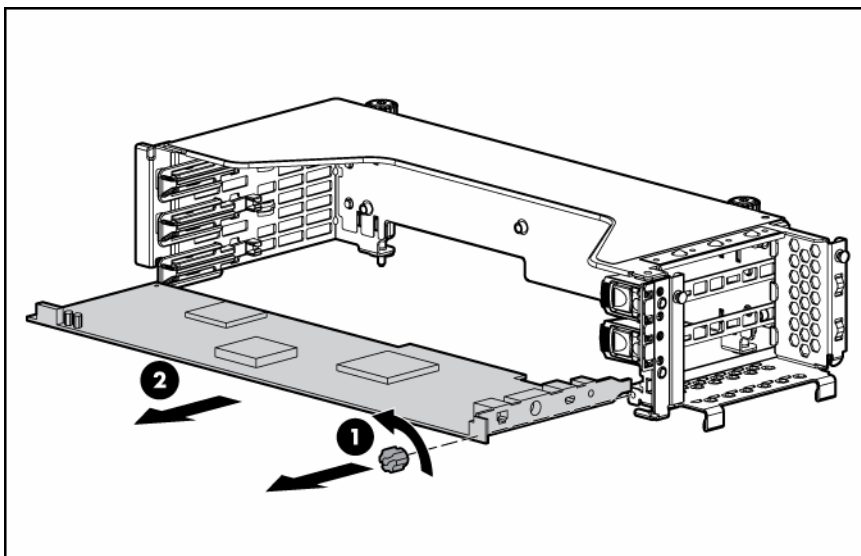

**△ CAUTION:** To prevent improper cooling and thermal damage, do not operate the server unless all PCI slots have either an expansion slot cover or an expansion board installed.

To replace the component, reverse the removal procedure.

## Expansion slot cover

To remove the component:

1. Power down the server (on page 20).
2. Extend or remove the server from the rack ("Extend the server from the rack" on page 19, "Remove the server from the rack" on page 20).
3. Remove the access panel ("Access panel" on page 22).

**△ CAUTION:** To prevent damage to the server or expansion boards, power down the server and remove all AC power cords before removing or installing the PCI riser cage.

4. Remove the PCI riser cage.



**CAUTION:** To prevent improper cooling and thermal damage, do not operate the server unless all PCI slots have either an expansion slot cover or an expansion board installed.

5. Remove the expansion slot cover.

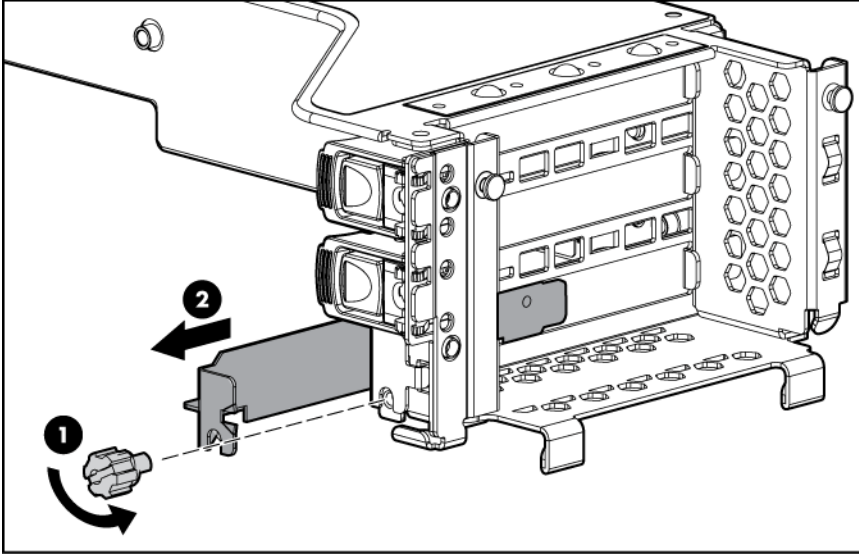

To replace the component, reverse the removal procedure.

## Expansion board ejector/divider

**NOTE:** This component is available only with the optional, hot-plug PCI riser cage.

To remove the component:

1. Power down the server (on page 20).
2. Extend or remove the server from the rack ("[Extend the server from the rack](#)" on page 19, "[Remove the server from the rack](#)" on page 20).
3. Remove the access panel ("[Access panel](#)" on page 22).
4. Remove the PCI riser cage.

**CAUTION:** To prevent damage to the server or expansion boards, power down the server and remove all AC power cords before removing or installing the PCI riser cage.

5. Remove the expansion board ejector/divider.

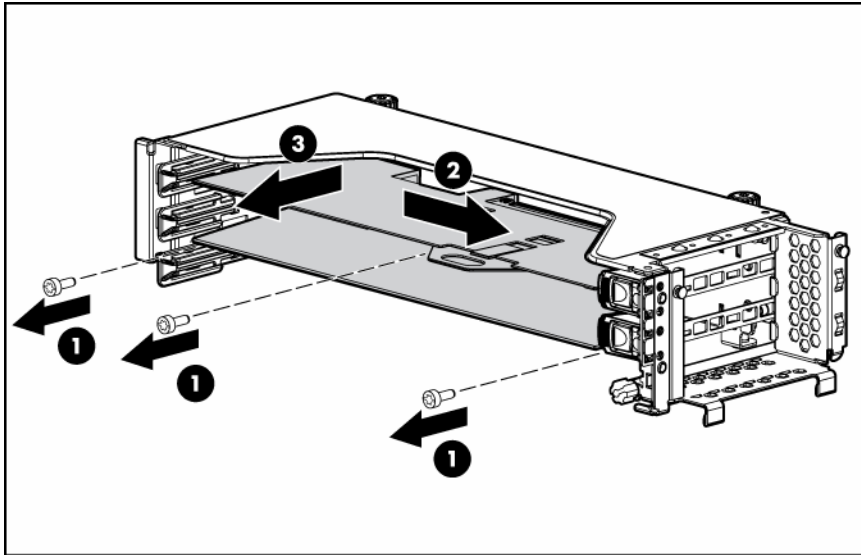

**CAUTION:** To prevent improper cooling and thermal damage, do not operate the server unless all PCI slots have either an expansion slot cover or an expansion board installed.

To replace the component, reverse the removal procedure.

## PCI slot release lever

To remove the component:

1. Power down the server (on page 20).
2. Extend or remove the server from the rack ("Extend the server from the rack" on page 19, "Remove the server from the rack" on page 20).
3. Remove the access panel ("Access panel" on page 22).

**CAUTION:** To prevent damage to the server or expansion boards, power down the server and remove all AC power cords before removing or installing the PCI riser cage.

4. Remove the PCI riser cage.

**CAUTION:** To prevent improper cooling and thermal damage, do not operate the server unless all expansion slots have either an expansion slot cover or an expansion board installed.

5. Remove the expansion board from the slot, if installed.
6. Remove the expansion slot cover from the slot, if installed.

7. Remove the PCI slot release lever.

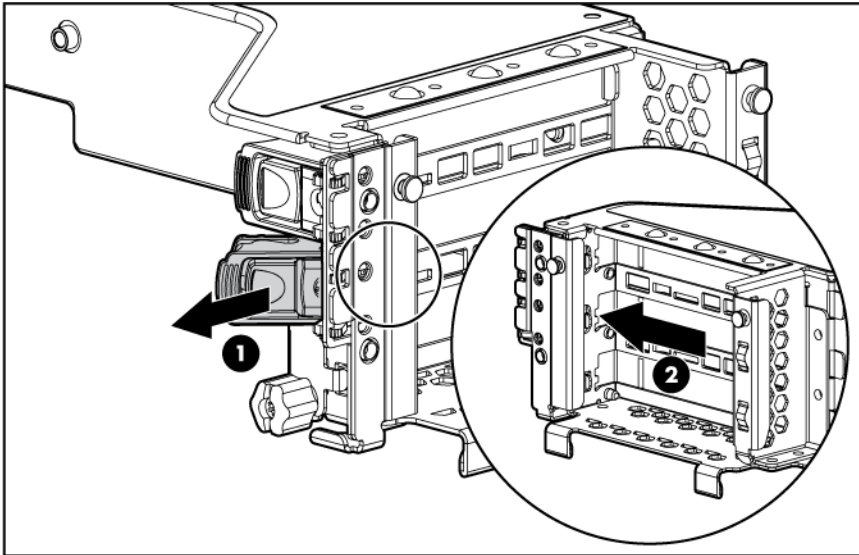

To replace the component, reverse the removal procedure.

## PCI lightpipe and cover

 **NOTE:** This component is available only with the optional, hot-plug PCI riser cage.

To remove the component:

1. Power down the server (on page 20).
2. Extend or remove the server from the rack ("Extend the server from the rack" on page 19, "Remove the server from the rack" on page 20).
3. Remove the access panel ("Access panel" on page 22).
4. Remove the PCI lightpipe cover.

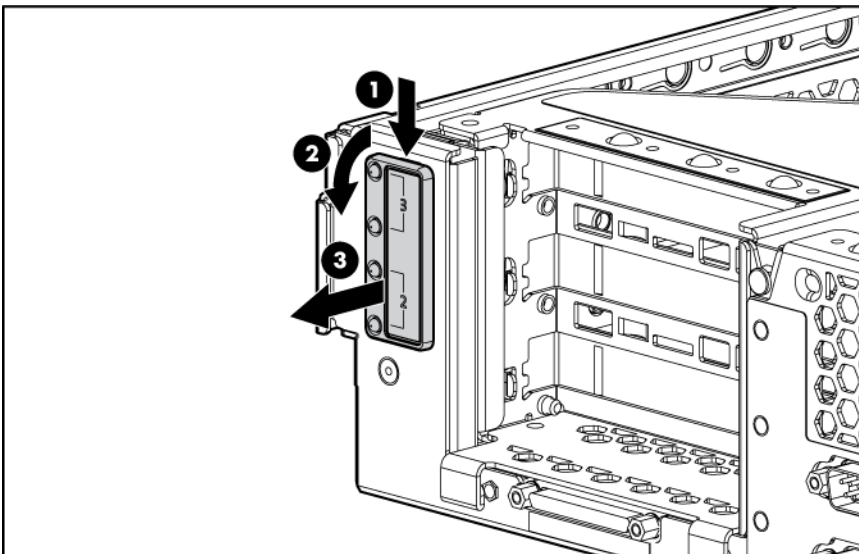

5. Slide the lightpipe out of the chassis.

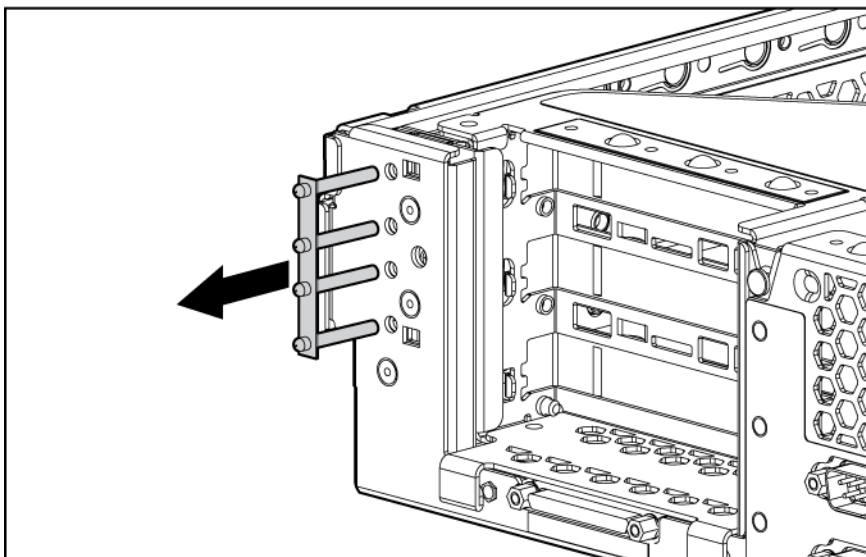

To replace the component, reverse the removal procedure.

## Power converter module

To remove the component:

1. Power down the server (on page 20).
2. Extend or remove the server from the rack ("[Extend the server from the rack](#)" on page 19, "[Remove the server from the rack](#)" on page 20).
3. Remove the access panel ("[Access panel](#)" on page 22).
4. Remove the front fan bracket ("[Front fan bracket](#)" on page 25).



**IMPORTANT:** For this procedure, you do not need to remove the hot-plug fans from the front fan bracket. When reinstalling the front fan bracket, press the top of each fan to be sure it seats securely.

5. Remove all hot-plug power supplies ("[Hot-plug power supply](#)" on page 47).
6. Disconnect all power cables.

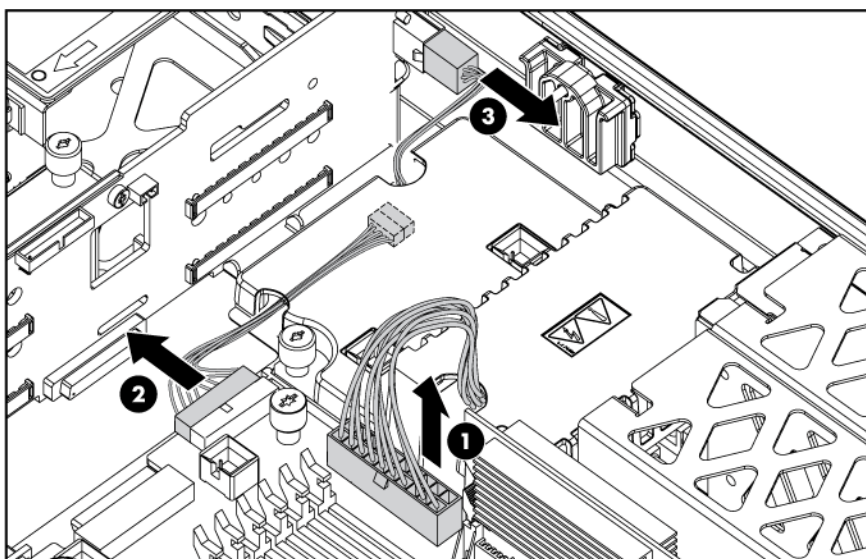

7. Remove the power converter module.

 **NOTE:** Cables are removed for clarity.

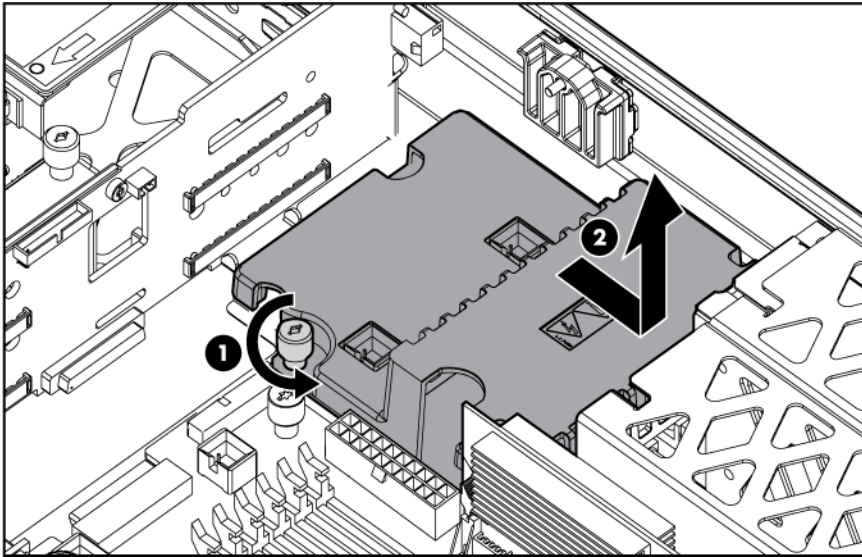

To replace the component, reverse the removal procedure.

## Power button/LED board

To remove the component:

1. Power down the server (on page 20).
2. Extend or remove the server from the rack ("Extend the server from the rack" on page 19, "Remove the server from the rack" on page 20).
3. Remove the front bezel.
4. Remove the access panel ("Access panel" on page 22).
5. Remove the BBWC battery pack.

 **NOTE:** This feature applies only to SCSI models.

6. Remove the power button/LED board.

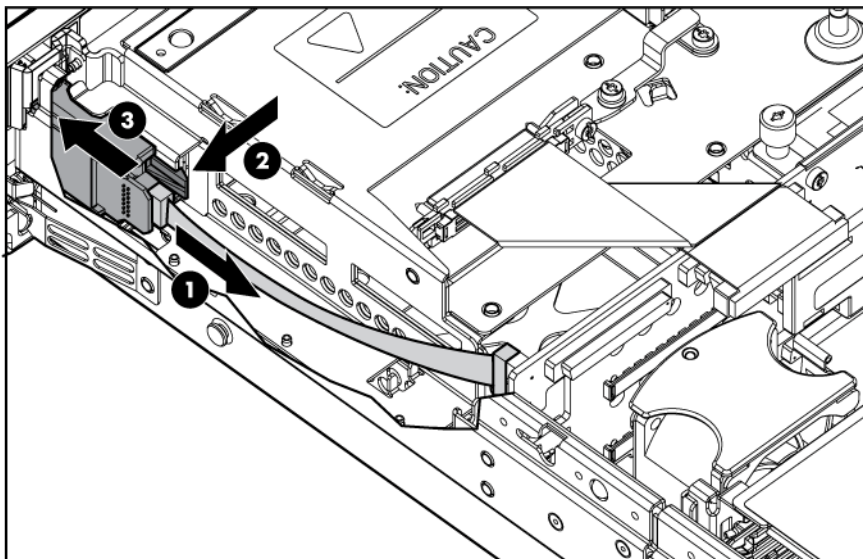

To replace the component, reverse the removal procedure.

## DIMMs

To remove the component:

1. Power down the server (on page 20).
2. Extend or remove the server from the rack ("Extend the server from the rack" on page 19, "Remove the server from the rack" on page 20).
3. Remove the access panel ("Access panel" on page 22).



**NOTE:** The server ships with at least two DIMMs installed in DIMM slots 1A and 2A.

4. Remove the DIMM.

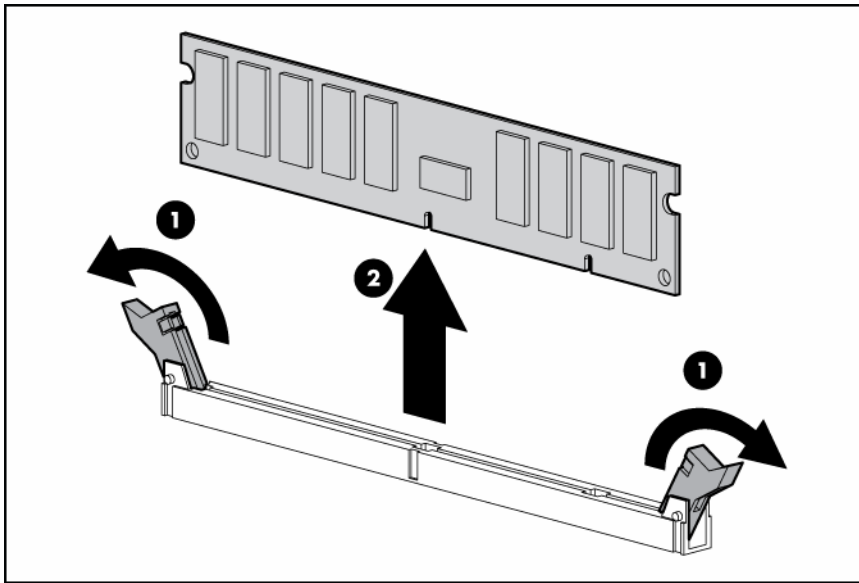

**CAUTION:** Be sure to install DIMMs in the proper configuration. Refer to the Documentation CD.

**CAUTION:** Use only Compaq branded or HP DIMMs. DIMMs from other sources may adversely affect data integrity.



**IMPORTANT:** DIMMs do not seat fully if turned the wrong way.

To replace a DIMM, align the DIMM with the slot and insert the DIMM firmly. When fully seated, the DIMM slot latches lock into place. The following table lists all seven valid combinations of single-rank and dual-rank DIMM configurations.

Configuration	Bank A	Bank B	Bank C	Notes
1	Single			
2	Single	Single		
3	Single	Single	Single	
4	Dual			Online Spare not supported
5	Dual	Single		Online Spare not supported
6	Dual	Single	Single	Online Spare not supported
7	Dual	Dual		Online Spare not supported

## PPM

To remove the component:

1. Power down the server (on page 20).
2. Extend or remove the server from the rack ("Extend the server from the rack" on page 19, "Remove the server from the rack" on page 20).
3. Remove the access panel ("Access panel" on page 22).



**NOTE:** The appearance of compatible PPMs may vary.

4. Remove the PPM.

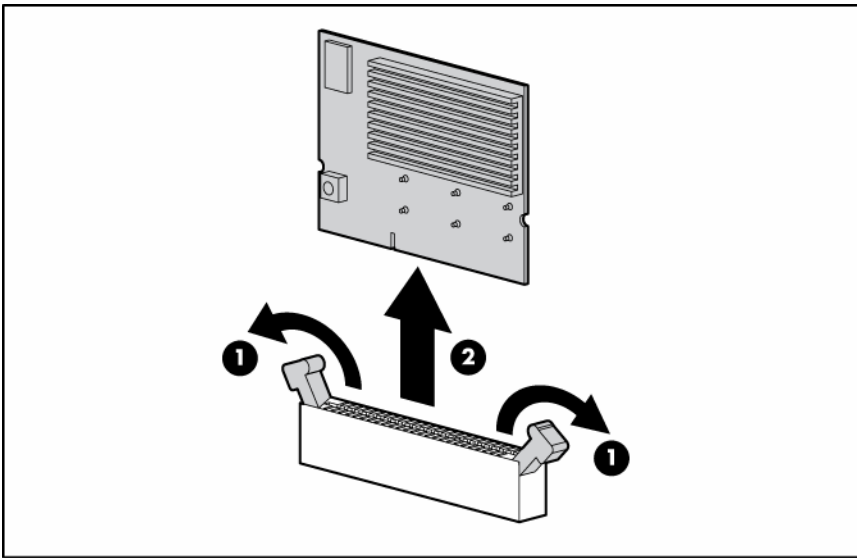

**IMPORTANT:** PPM slots must be populated when processors are installed. If PPM slots are not populated, the server halts during POST or does not boot.

To replace the component, reverse the removal procedure.

## Processor

To remove the component:

1. Power down the server (on page 20).
2. Extend or remove the server from the rack ("Extend the server from the rack" on page 19, "Remove the server from the rack" on page 20).
3. Remove the access panel ("Access panel" on page 22).
4. If an optional redundant fan is located next to the processor, remove the fan ("Hot-plug fan" on page 49).



5. Open the processor retaining bracket.

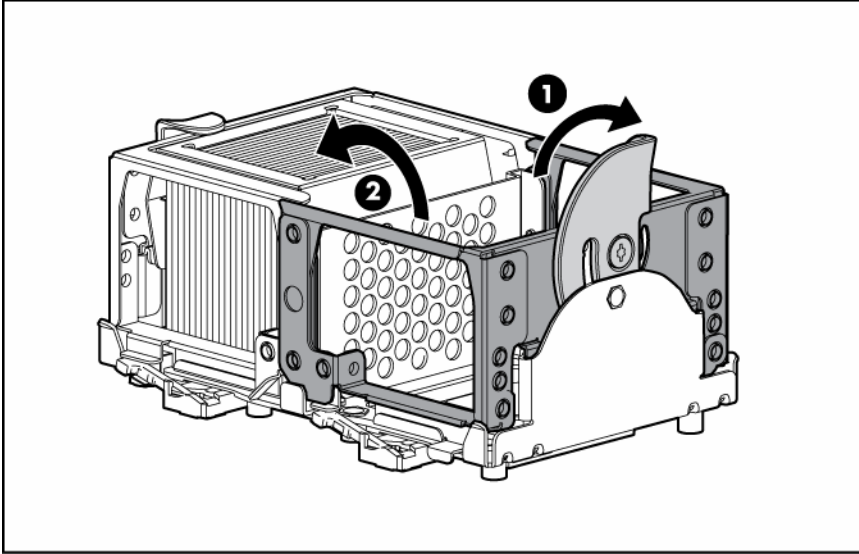

**CAUTION:** To prevent thermal instability and damage to the server, do not separate the processor from the heatsink. The processor, heatsink, and retaining clip make up a single assembly.

6. Remove the processor and heatsink assembly.

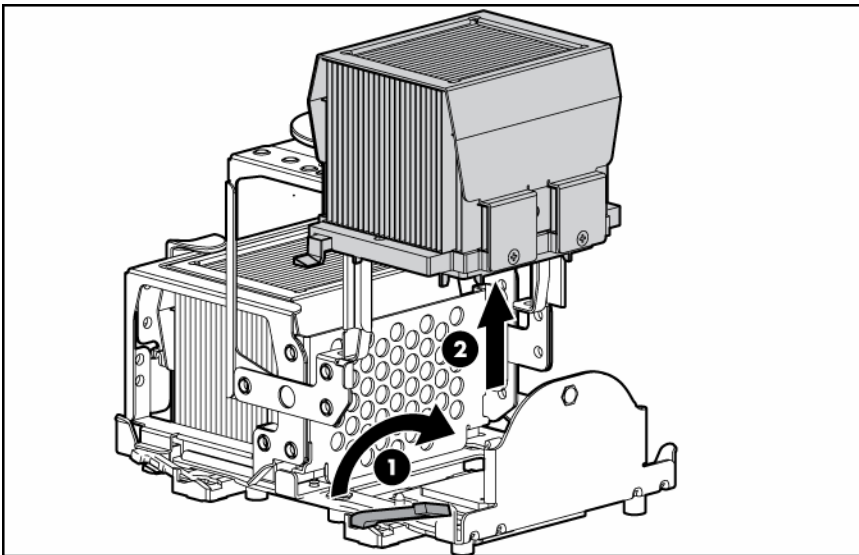

**CAUTION:** To prevent possible server malfunction and damage to the equipment, do not mix single- and dual-core processors or processors with different speeds or cache sizes.

**CAUTION:** Failure to completely open the processor locking lever prevents the processor from seating during installation, leading to hardware damage.

**CAUTION:** When installing a processor, be sure to secure the processor using the processor socket lever before closing the processor retaining bracket. Failure to do so will result in physical damage to the processor and server.

**CAUTION:** To prevent possible server malfunction or damage to the equipment, be sure to align the processor pins with the corresponding holes in the socket.

**CAUTION:** To prevent possible server malfunction or damage to the equipment, be sure to completely close the processor locking lever.



 **IMPORTANT:** If upgrading processor speed, update the system ROM before installing the processor.

 **IMPORTANT:** Processor socket 1 and PPM slot 1 must be populated at all times or the server does not function properly.

 **IMPORTANT:** PPM slots must be populated when processors are installed. If PPM slots are not populated, the server halts during POST or does not boot.

 **IMPORTANT:** If you replace a failed processor or processors, clear the status log in RBSU after powering up the server. For RBSU procedures, refer to the Documentation CD.

To replace the component, reverse the removal procedure.

## Battery

If the server no longer automatically displays the correct date and time, you may need to replace the battery that provides power to the real-time clock.

 **WARNING:** The computer contains an internal lithium manganese dioxide, a vanadium pentoxide, or an alkaline battery pack. A risk of fire and burns exists if the battery pack is not properly handled. To reduce the risk of personal injury:

- Do not attempt to recharge the battery.
- Do not expose the battery to temperatures higher than 60°C (140°F).
- Do not disassemble, crush, puncture, short external contacts, or dispose of in fire or water.
- Replace only with the spare designated for this product.

To remove the component:

1. Power down the server (on page 20).
2. Extend or remove the server from the rack ("[Extend the server from the rack](#)" on page 19, "[Remove the server from the rack](#)" on page 20).
3. Remove the access panel ("[Access panel](#)" on page 22).
4. Remove the PCI riser cage.

 **CAUTION:** To prevent damage to the server or expansion boards, power down the server and remove all AC power cords before removing or installing the PCI riser cage.

5. Remove the battery.

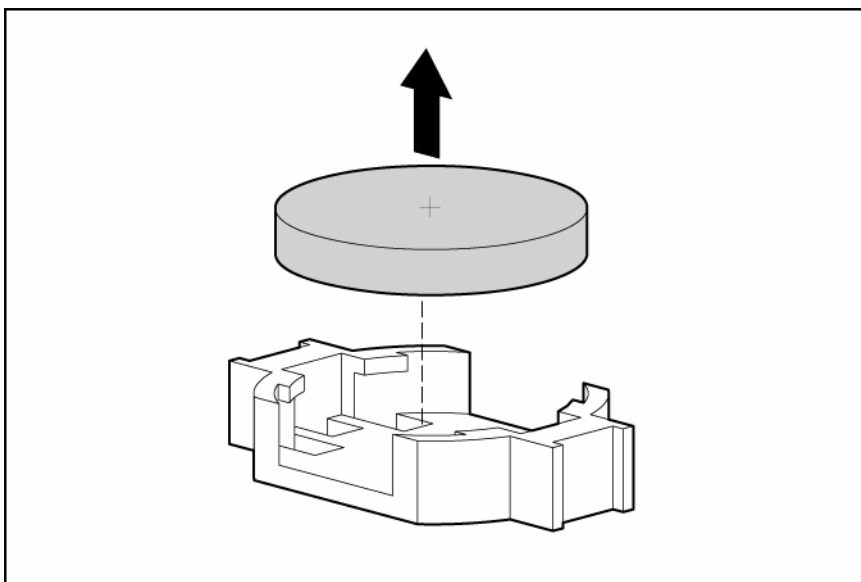

 **IMPORTANT:** Replacing the system board battery resets the system ROM to its default configuration. After replacing the battery, reconfigure the system through RBSU.

To replace the component, reverse the removal procedure.

For more information about battery replacement or proper disposal, contact an authorized reseller or an authorized service provider.

## System board

To remove the component:

1. Power down the server (on page 20).
2. Extend or remove the server from the rack ("[Extend the server from the rack](#)" on page 19, "[Remove the server from the rack](#)" on page 20).
3. Remove the access panel ("[Access panel](#)" on page 22).

 **CAUTION:** To prevent damage to the server or expansion boards, power down the server and remove all AC power cords before removing or installing the PCI riser cage.

4. Remove the PCI riser cage.
5. Remove the front fan bracket ("[Front fan bracket](#)" on page 25).

 **IMPORTANT:** For this procedure, you do not need to remove the hot-plug fans from the front fan bracket. When reinstalling the front fan bracket, press the top of each fan to be sure it seats securely.

6. Remove the hot-plug fans from the rear fan bracket ("[Hot-plug fan](#)" on page 49).
7. Remove any DDR SDRAM DIMMs ("[DIMMs](#)" on page 38).
8. Remove the processors.
9. Remove the PPMs.
10. Remove the Smart Array 6i cache module.

 **NOTE:** This feature applies only to SCSI models.

11. Disconnect all cables connected to the system board.

12. Identify the alignment keys and keyhole locations, 1 through 4.

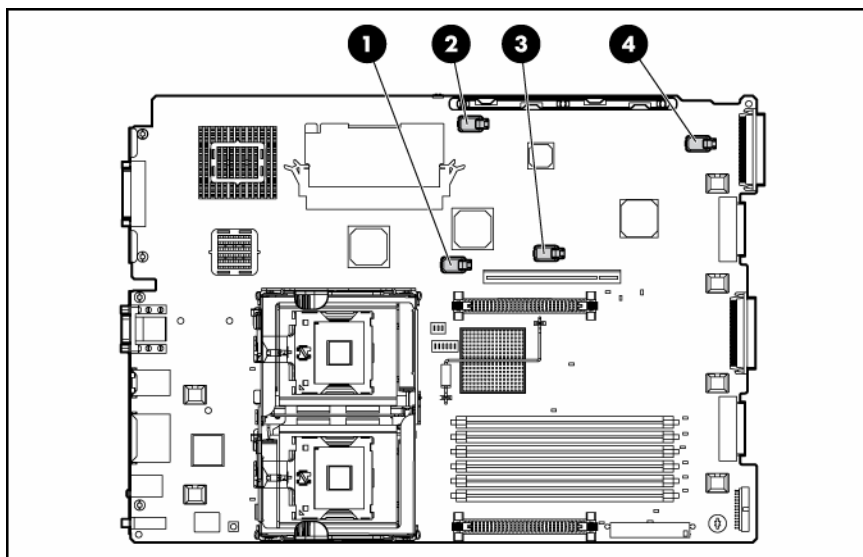

13. Loosen the system board thumbscrew.

14. Remove the system board.

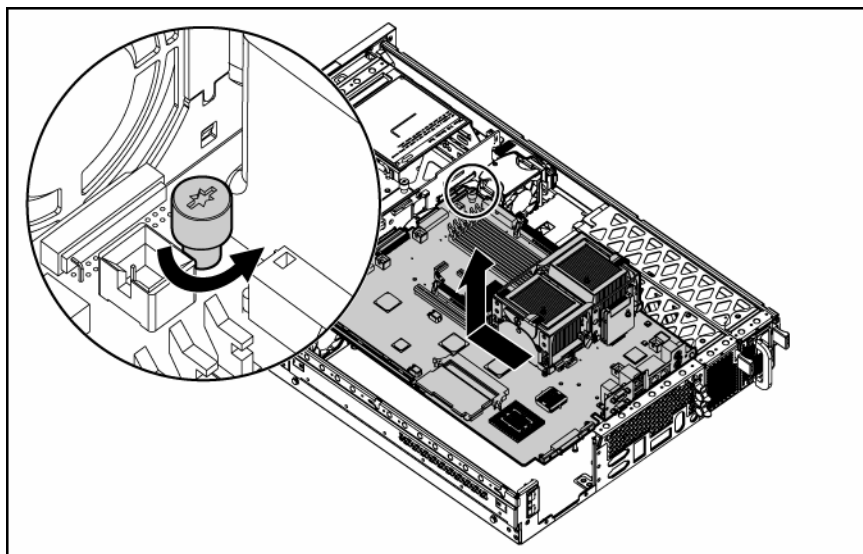

15. Remove the rear fan bracket.



**IMPORTANT:** If replacing the system board or clearing NVRAM, you must re-enter the server serial number through RBSU ("[Re-entering the server serial number and product ID](#)" on page 43).

To replace the component, reverse the removal procedure.

## Re-entering the server serial number and product ID

After you replace the system board, you must re-enter the server serial number and the product ID.

1. During the server startup sequence, press the **F9** key to access RBSU.
2. Select the **System Options** menu.
3. Select **Serial Number**. The following warning is displayed:

WARNING! WARNING! WARNING! The serial number is loaded into the system during the manufacturing process and should NOT be modified. This option

should only be used by qualified service personnel. This value should always match the serial number sticker located on the chassis.

4. Press the **Enter** key to clear the warning.
5. Enter the serial number and press the **Enter** key.
6. Select **Product ID**.
7. Enter the product ID and press the **Enter** key.
8. Press the **Esc** key to close the menu.
9. Press the **Esc** key to exit RBSU.
10. Press the **F10** key to confirm exiting RBSU. The server will automatically reboot.

## Hot-plug procedures

### Hot-plug SCSI hard drive

To remove the component:

**CAUTION:** To prevent improper cooling and thermal damage, do not operate the server unless all bays are populated with either a component or a blank.

1. Determine the status of the hard drive from the hot-plug hard drive LEDs ("Hot-plug SCSI hard drive LEDs" on page 85).
2. Back up all server data on the hard drive.
3. Remove the hard drive.

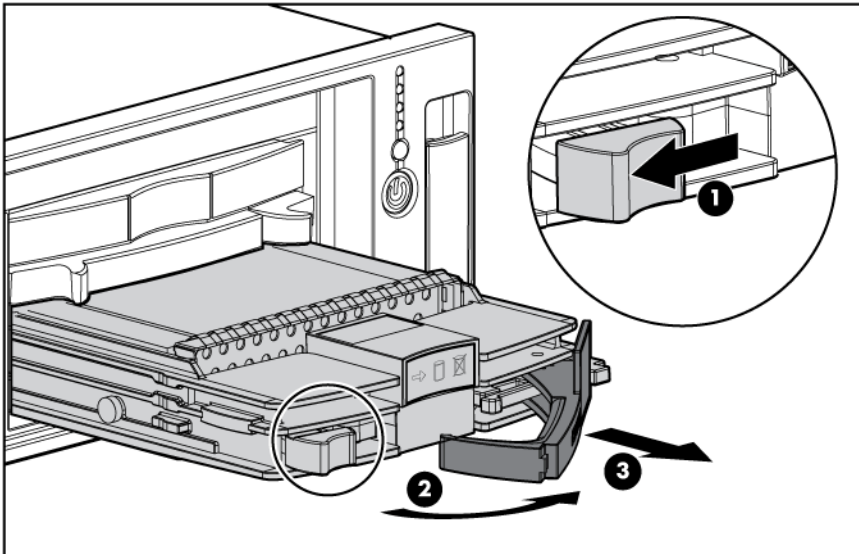

To replace the component, reverse the removal procedure.

### SCSI hard drive blank

To remove the component:

**CAUTION:** To prevent improper cooling and thermal damage, do not operate the server unless all bays are populated with either a component or a blank.

 **NOTE:** The server ships standard with five hard drive blanks.

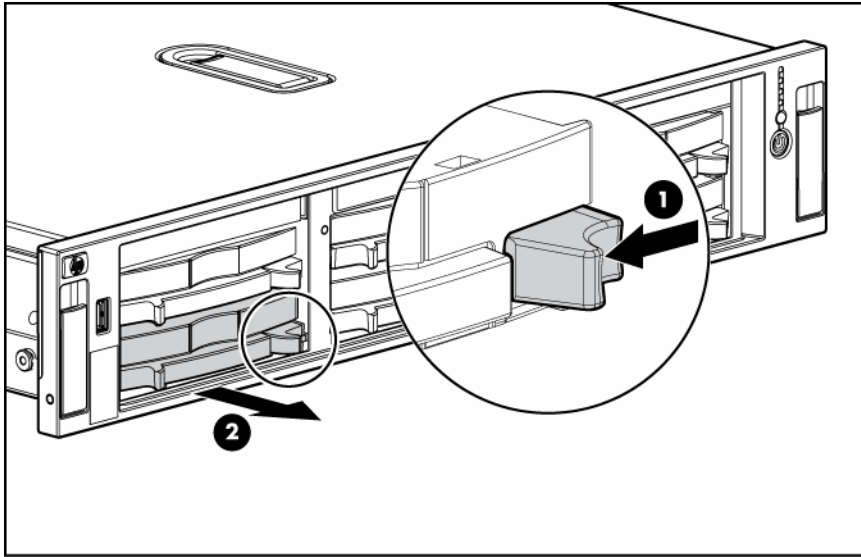

To replace the blank, slide the blank into the bay until it locks into place.

## Hot-plug SAS hard drive

To remove the component:

 **CAUTION:** To prevent improper cooling and thermal damage, do not operate the server unless all bays are populated with either a component or a blank.

1. Determine the status of the hard drive from the hot-plug SAS hard drive LED combinations (on page 87).
2. Back up all server data on the hard drive.
3. Remove the hard drive.

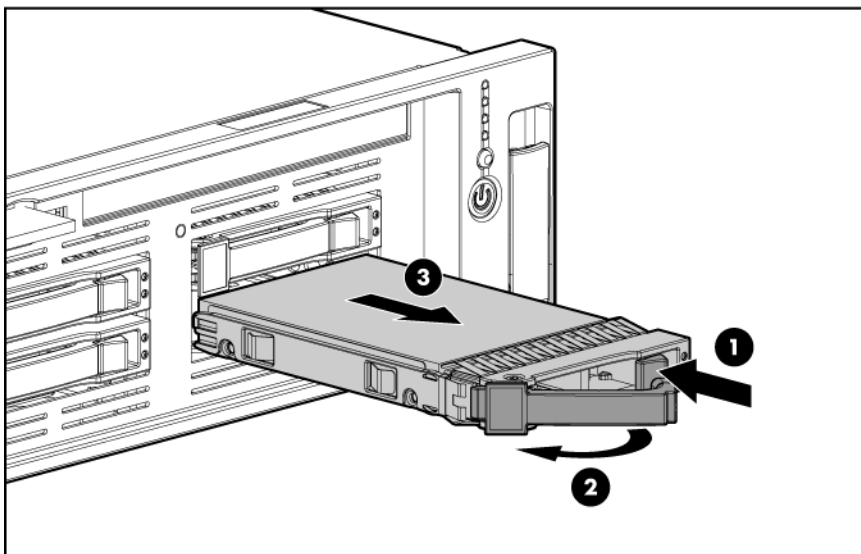

To replace the component, reverse the removal procedure.

## SAS hard drive blank

To remove the component:

- ⚠ **CAUTION:** To prevent improper cooling and thermal damage, do not operate the server unless all bays are populated with either a component or a blank.

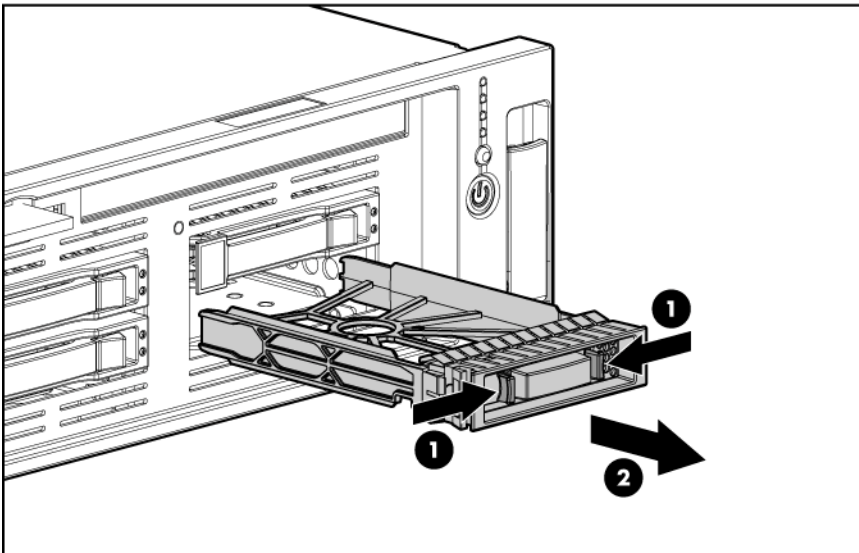

To replace the blank, slide the blank into the bay until it locks into place.

## Universal hot-plug tape drive

- 📝 **NOTE:** This feature applies only to SCSI models.

To remove the component:

- ⚠ **CAUTION:** To prevent improper cooling and thermal damage, do not operate the server unless all bays are populated with either a component or a blank.

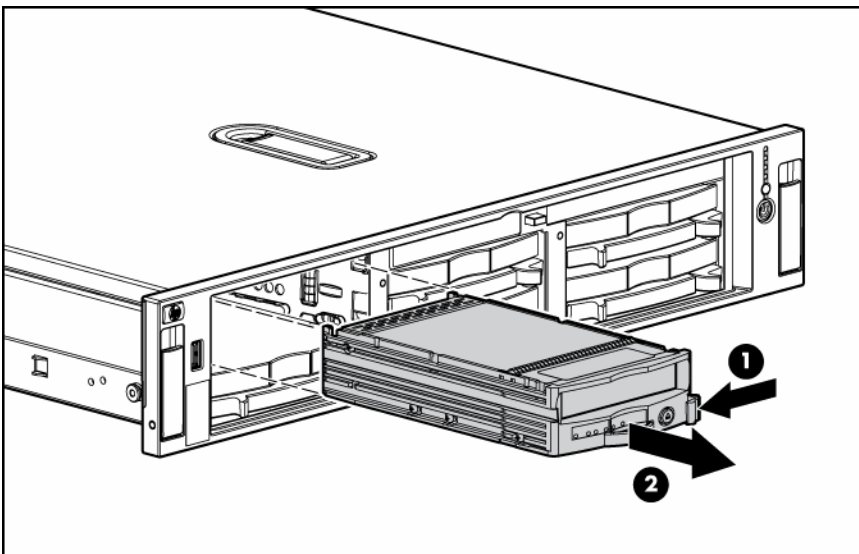

To replace the component, slide the drive into the bay until it locks into place.

## Tape drive blank

 **NOTE:** This feature applies only to SCSI models.

To remove the component:

 **CAUTION:** To prevent improper cooling and thermal damage, do not operate the server unless all bays are populated with either a component or a blank.

1. Reach underneath and squeeze the middle of the tape drive blank.
2. Pull the blank out of the bay.

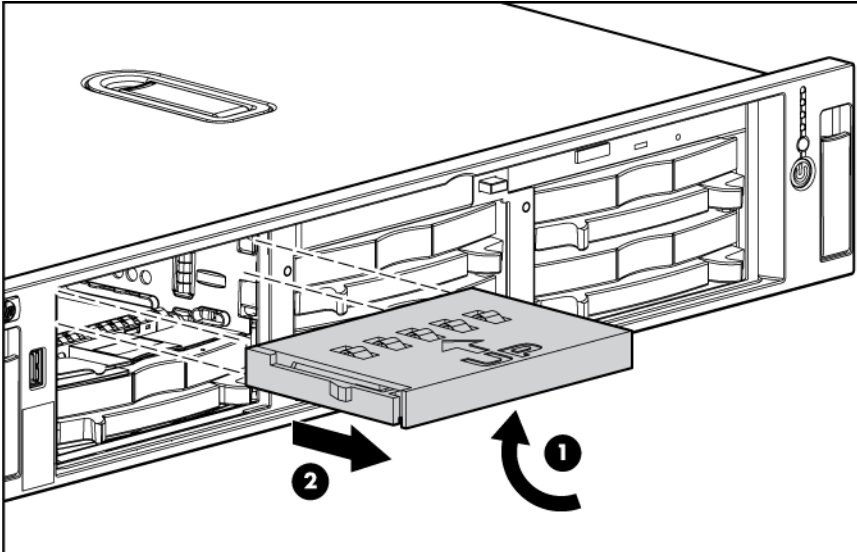

To replace the blank, slide the blank into the bay until it locks into place.

## Hot-plug power supply

To remove the component:

 **CAUTION:** To prevent improper cooling and thermal damage, do not operate the server unless all bays are populated with either a component or a blank.

1. Determine how many hot-plug power supplies are installed:
  - If only one hot-plug power supply is installed, power down and remove the power cord from the server ("[Power down the server](#)" on page 20).
  - If more than one hot-plug power supply is installed, continue with the next step.
2. Do one of the following:
  - If the cable management arm is hinged on the left side, proceed by opening the cable management arm ("[Cable management arm with left-hand swing](#)" on page 21).
  - If the cable management arm is hinged on the right side, proceed by removing the cable management arm ("[Non-hot-plug procedures](#)" on page 22).

3. Remove the hot-plug power supply.

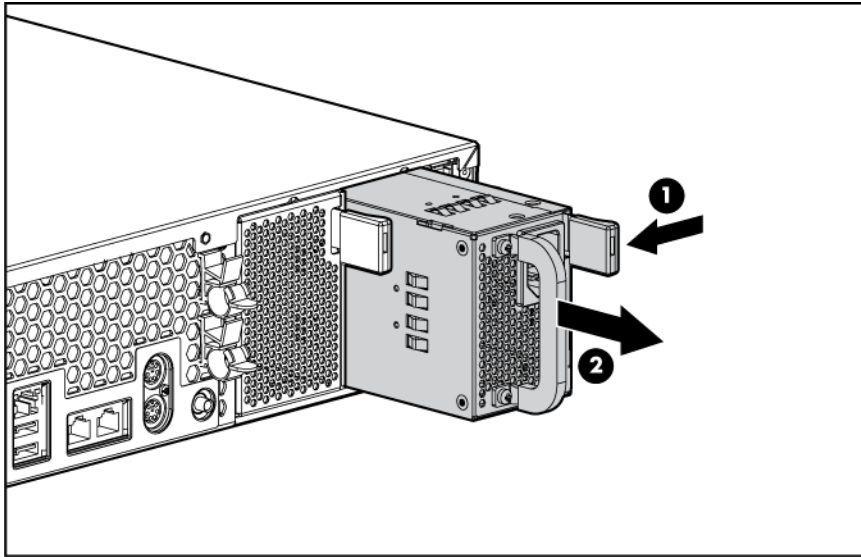

To replace the component:

**⚠ WARNING:** To reduce the risk of electric shock or damage to the equipment, do not connect the power cord to the power supply until the power supply is installed.

1. Slide the hot-plug power supply into the power supply bay.
2. Connect the power cord to the power supply.
3. Install the cable management arm, if removed. ("[Access the product rear panel](#)" on page 21)
4. Route the power cord through the cable management arm or power cord anchor.

**📝 NOTE:** If using the power cord anchor, be sure to leave enough slack in the power cord so that the redundant power supply can be removed without disconnecting the power cord from the primary power supply.

5. Close the cable management arm.
6. Connect the power cord to the power source.
7. Be sure that the power supply LED is green ("[Rear panel LEDs and buttons](#)" on page 78).
8. Be sure that the front panel external health LED is green ("[Front panel LEDs and buttons](#)" on page 76).

## Power supply blank

To remove the component:

**⚠ CAUTION:** To prevent improper cooling and thermal damage, do not operate the server unless all bays are populated with either a component or a blank.

1. Do one of the following:
  - If the cable management arm is hinged on the left side, proceed by opening the cable management arm ("[Cable management arm with left-hand swing](#)" on page 21).
  - If the cable management arm is hinged on the right side, proceed by removing the cable management arm ("[Non-hot-plug procedures](#)" on page 22).
2. Remove the power supply blank.



**⚠ WARNING:** To reduce the risk of personal injury from hot surfaces, allow the power supply or power supply blank to cool before touching it.

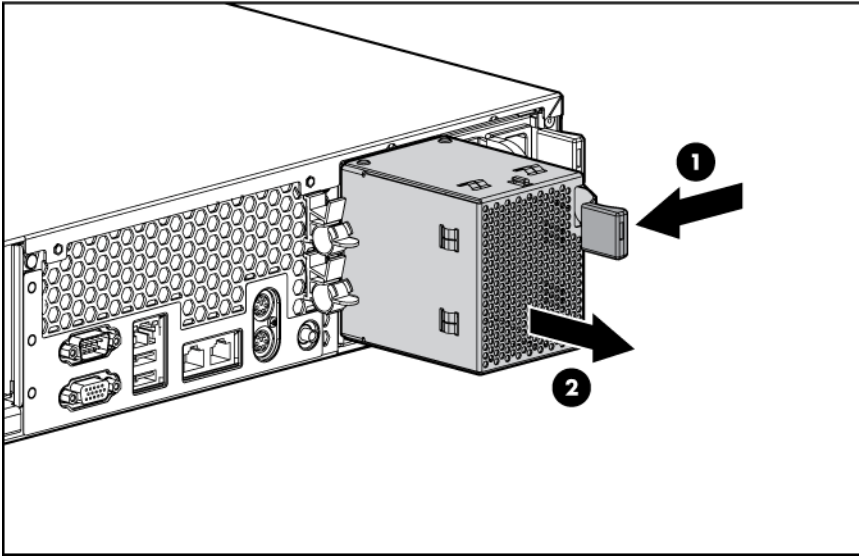

To replace the blank, slide the blank into the bay until it locks into place.

## Hot-plug fan

**⚠ WARNING:** To reduce the risk of electric shock, personal injury, and damage to the equipment:

- **Do not attempt to service any parts of the equipment other than those specified in the following procedure. Any other activities may require that you shut down the server and remove the power cord.**
- **Installation and maintenance of this product must be performed by individuals who are knowledgeable about the procedures, precautions and hazards associated with the product.**

You must observe the following requirements when installing redundant hot-plug fans:

- To ensure optimum cooling, populate the primary fan locations, 2, 4, 5, 6, and 7, before populating the redundant locations ("[Identifying hot-plug fans](#)" on page 90).
- If a primary fan fails, replace the non-functioning fan before installing fans in redundant locations ("[Identifying hot-plug fans](#)" on page 90).

To remove the component:

1. Extend or remove the server from the rack ("[Extend the server from the rack](#)" on page 19, "[Remove the server from the rack](#)" on page 20).
2. Remove the access panel ("[Access panel](#)" on page 22).
3. If the server is operating with less than seven functional fans, power down the server (on page 20), then continue with the next step.

4. Remove the non-functioning fan.

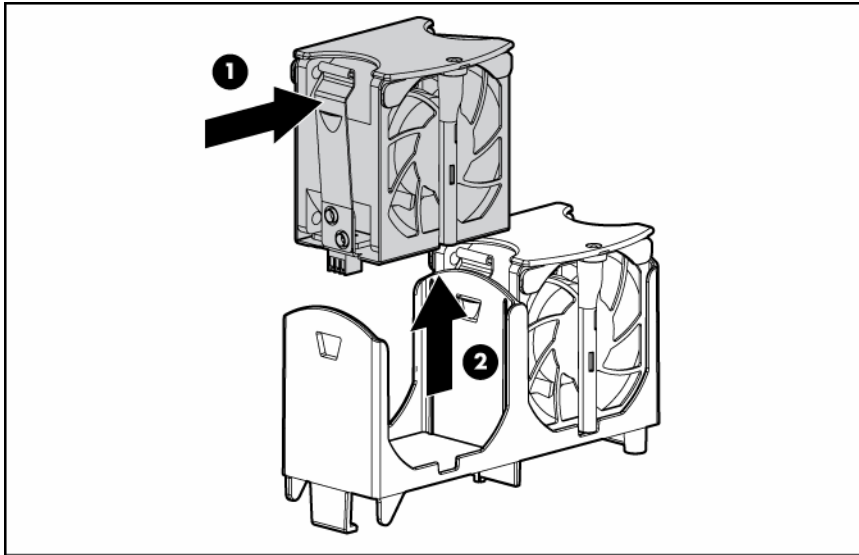

**CAUTION:** Do not operate the server for long periods with the access panel open or removed. Operating the server in this manner results in improper airflow and improper cooling that can lead to thermal damage.

**IMPORTANT:** For optimum cooling, install fans in all primary fan locations. For more information, refer to the fan locations table ("[Identifying hot-plug fans](#)" on page 90).

To replace the component, reverse the removal procedure.

## PCI Hot Plug expansion board

**NOTE:** Hot-plug functionality is supported only under Microsoft® Windows® 2000 and Windows® 2003. Hot-plug drivers are not required.

To remove the component:

**CAUTION:** If the operating system installed on the server does not support PCI Hot Plug functionality, power down the server before removing expansion boards.

1. Extend or remove the server from the rack ("[Extend the server from the rack](#)" on page 19, "[Remove the server from the rack](#)" on page 20).
2. Remove the access panel ("[Access panel](#)" on page 22).

3. Open the PCI riser cage door.

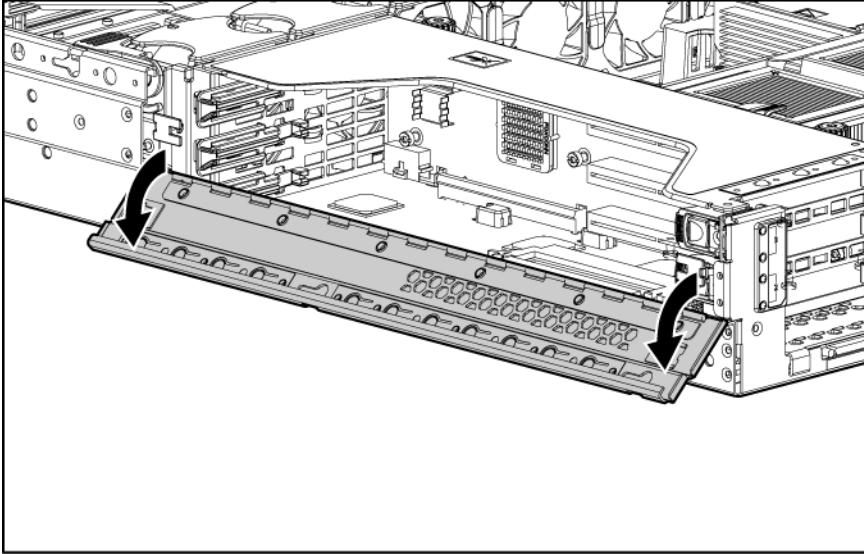

4. Press the PCI Hot Plug button ("Internal PCI Hot Plug LEDs and button" on page 90) to remove power from the slot. When the green power LED on the slot stops flashing, power has been removed from the slot.
5. Unlock the PCI retaining clip.

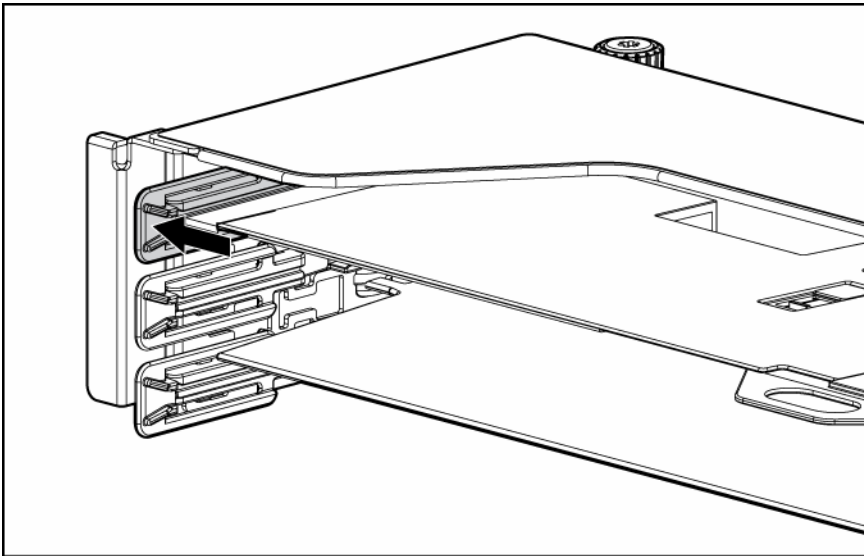

**CAUTION:** To prevent improper cooling and thermal damage, do not operate the server unless all PCI slots have either an expansion slot cover or an expansion board installed.

6. Remove the expansion board.

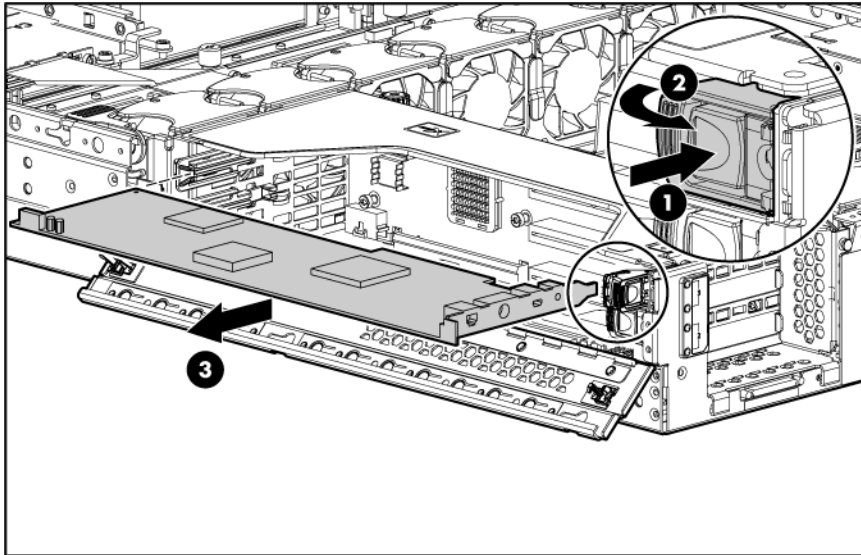

To replace the component, reverse the removal procedure.

## PCI Hot Plug expansion slot cover

**NOTE:** Hot-plug functionality is supported only under Microsoft® Windows® 2000 and Windows® 2003. Hot-plug drivers are not required.

To remove the component:

**⚠ CAUTION:** If the operating system installed on the server does not support PCI Hot Plug functionality, power down the server (on page 20) before removing expansion boards.

1. Extend or remove the server from the rack ("Extend the server from the rack" on page 19, "Remove the server from the rack" on page 20).
2. Remove the access panel ("Access panel" on page 22).
3. Open the PCI riser cage door.

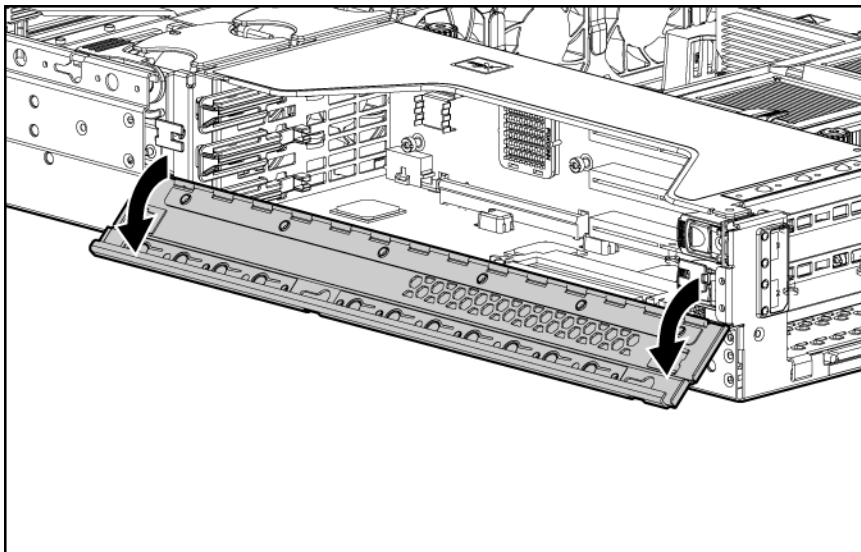

4. Press the PCI Hot Plug button ("[Internal PCI Hot Plug LEDs and button](#)" on page 90) to remove power from the slot. When the green power LED on the slot stops flashing, power has been removed from the slot.

**CAUTION:** To prevent improper cooling and thermal damage, do not operate the server unless all PCI slots have either an expansion slot cover or an expansion board installed.

5. Remove the expansion slot cover.

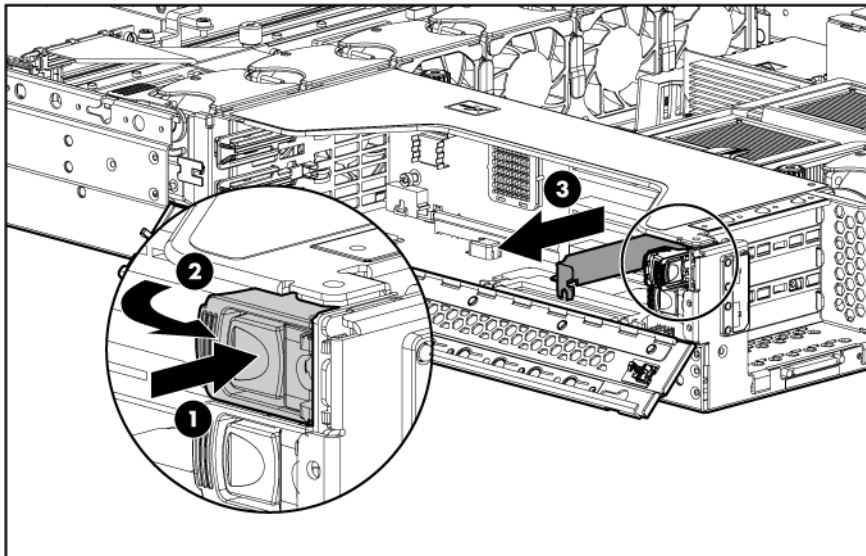

To replace the component, reverse the removal procedure.

---

# Cabling

## In this section

Cabling.....	54
SAS model cabling.....	54
SCSI model cabling.....	58

## Cabling

This section provides guidelines that help you make informed decisions about cabling the server and hardware options to optimize performance.

For information on cabling the optional RILOE II board, refer to the *HP Remote Insight Lights-Out Edition II User Guide* on the Documentation CD.

For information on cabling peripheral components, refer to the white paper on high-density deployment in HP or Compaq branded racks on the HP website (<http://www.hp.com>).

## SAS model cabling

### SAS hard drive cabling

The HP ProLiant DL380 Generation 4 Server Service and Maintenance Guide SAS model uses a serial attached SCSI bus to connect SAS hard drives on a SAS backplane to a PCI SAS controller. In a SAS environment, each hard drive has a direct connection to the SAS controller. Two cables connect the PCI SAS controller to the SAS backplane. Each cable controls four SAS drives.



**NOTE:** If storage devices are connected to both the internal (1I) and external (1E) SAS connectors, the SAS controller recognizes only the devices connected to the internal connector. To attach devices to the external connector, disconnect the internal connector. Refer to the documentation that documentation that ships with the controller.

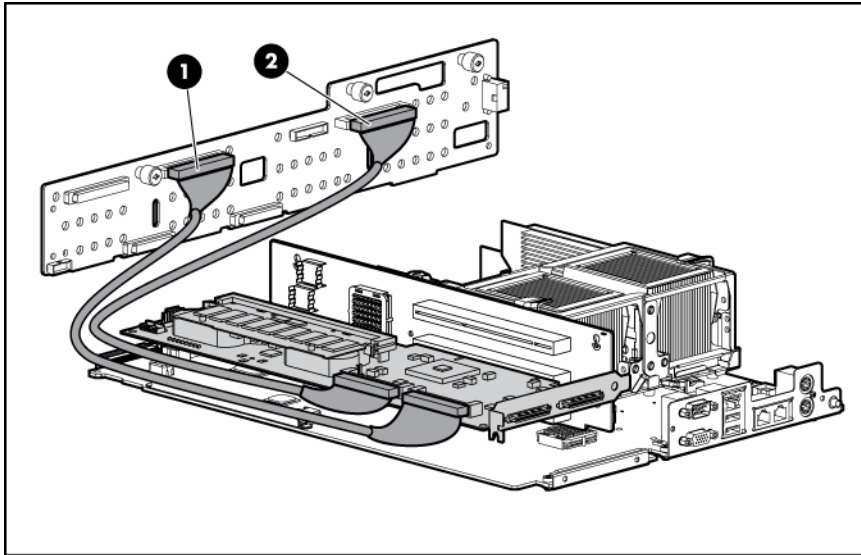

Item	Description
1	SAS connector 1
2	SAS connector 2

## USB cabling

The USB cable connects the front panel USB connector to the SAS backplane.

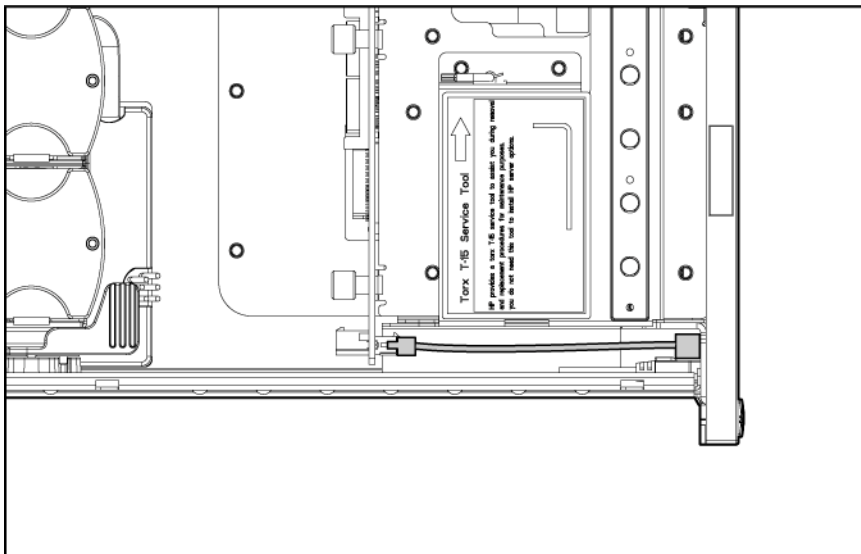



### DVD/CD-ROM drive cabling

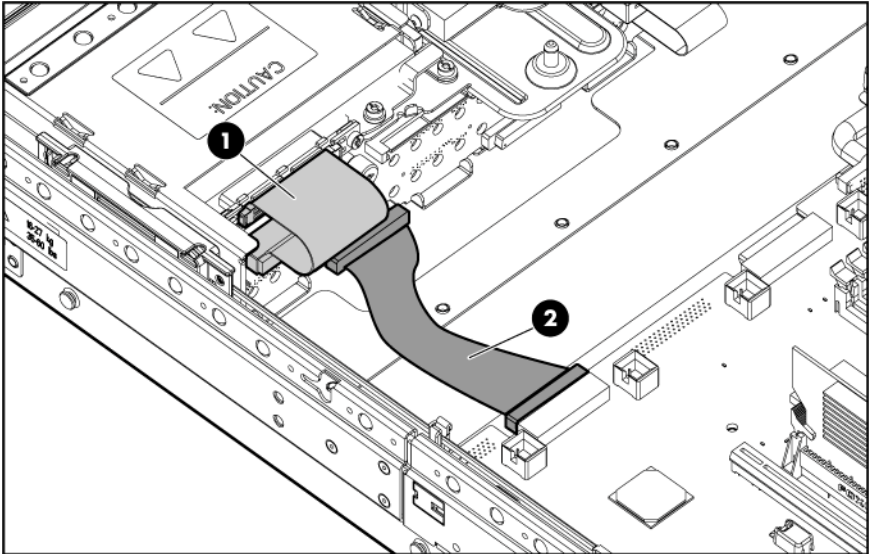

Item	Cable description
1	DVD/CD-ROM drive cable
2	DVD/CD-ROM drive system cable

### Diskette drive cabling

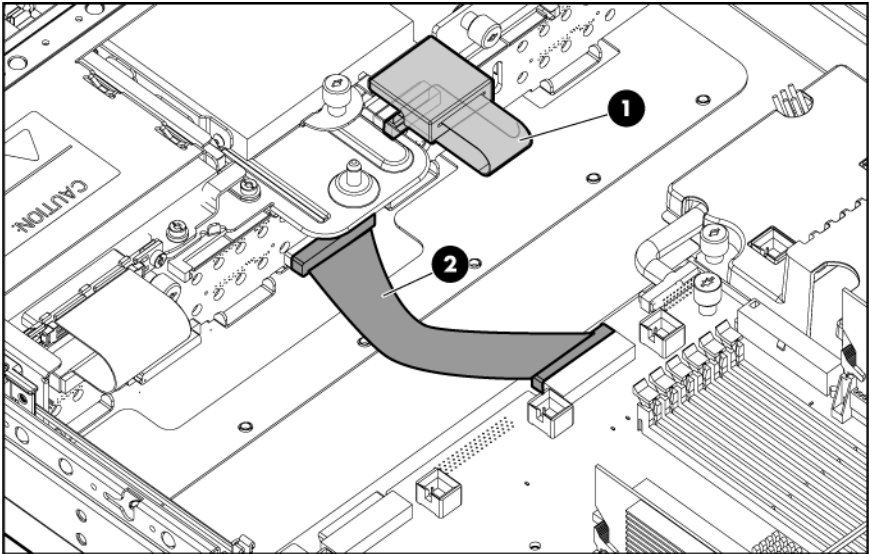

Item	Cable description
1	Diskette drive cable
2	Diskette drive system cable



## Power button/LED cabling

The power button/LED cable connects the power button/LED board to the SAS backplane.

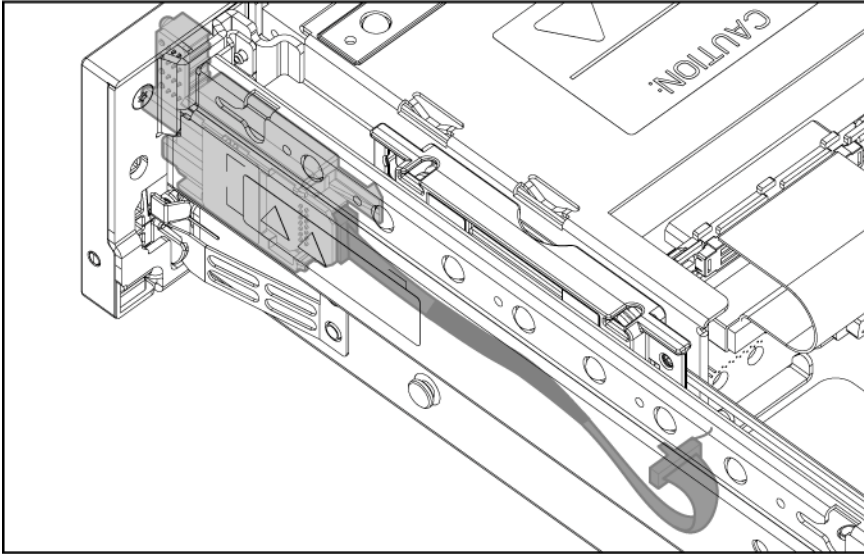

## Optional PCI Hot Plug backplane cabling

The server contains a PCI Hot Plug backplane that is part of the PCI Hot Plug option and provides hot-plug capability for two expansion slots. A ribbon cable connects the PCI Hot Plug backplane to the riser board.

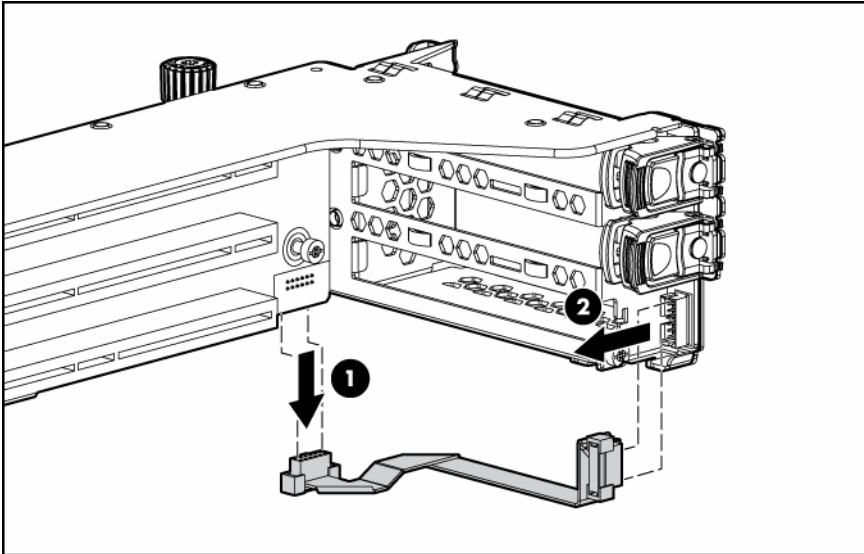

## RILOE II cabling

The 30-pin Remote Insight cable ships with the RILOE II cable kit. For more information, refer to the *Remote Insight Lights-Out Edition II User Guide* on the Documentation CD.

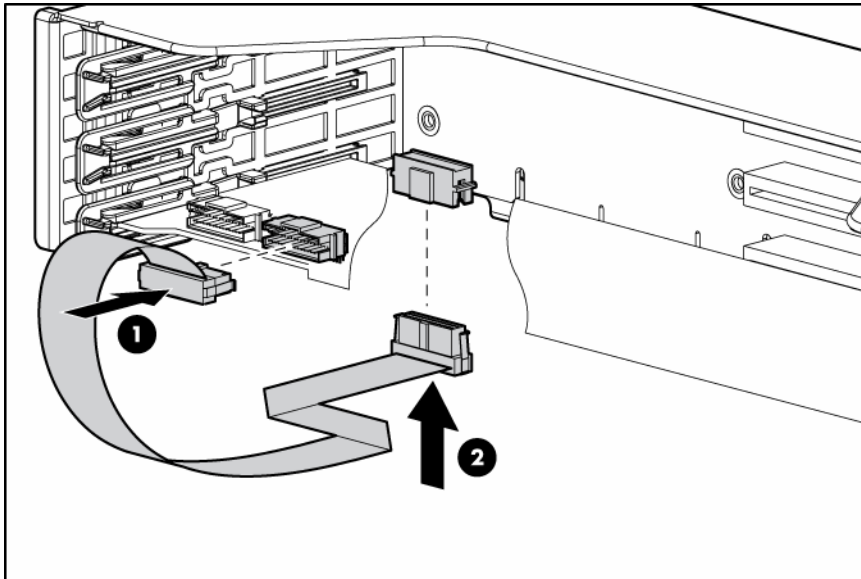

## Internal power cabling

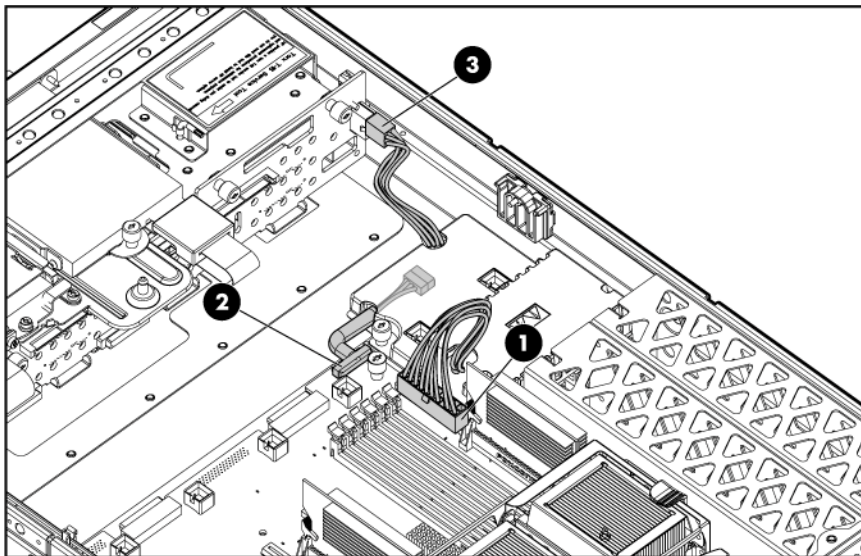

Item	Description
1	System power cable
2	Power supply signal cable
3	SAS power cable

## SCSI model cabling

**IMPORTANT:** If a simplex or duplex cabling configuration is not cabled correctly, the SCSI configuration error LED will illuminate. Refer to "SCSI Backplane LEDs (on page 85)" to locate the LED.

 **NOTE:** The server ships with two identical short SCSI cables. Two optional long SCSI cables may be obtained for PCI Array Controllers. One optional terminator board may be obtained to support duplex SCSI configurations.

## Embedded simplex SCSI cabling

In the embedded simplex cabling configuration, the embedded Smart Array 6i Controller controls up to six hard drives through one SCSI bus. The server ships standard with this configuration.

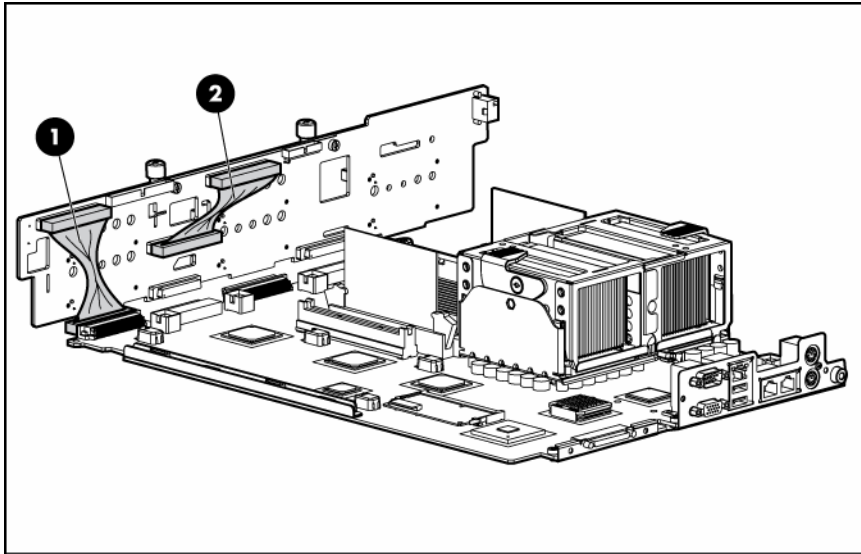

 **NOTE:** The short SCSI cables are identical.

Item	Component description	SCSI IDs managed
1	Short SCSI cable	0, 1, 2, 3, 4, 5
2	Short SCSI cable used to jumper the two SCSI buses together	N/A

## Embedded duplex SCSI cabling

In the embedded duplex cabling configuration, the embedded Smart Array 6i Controller controls up to six hard drives through two SCSI buses: one bus with up to two drives and the other bus with up to four drives.

 **NOTE:** This specific cabling configuration does not support external VHDCI.

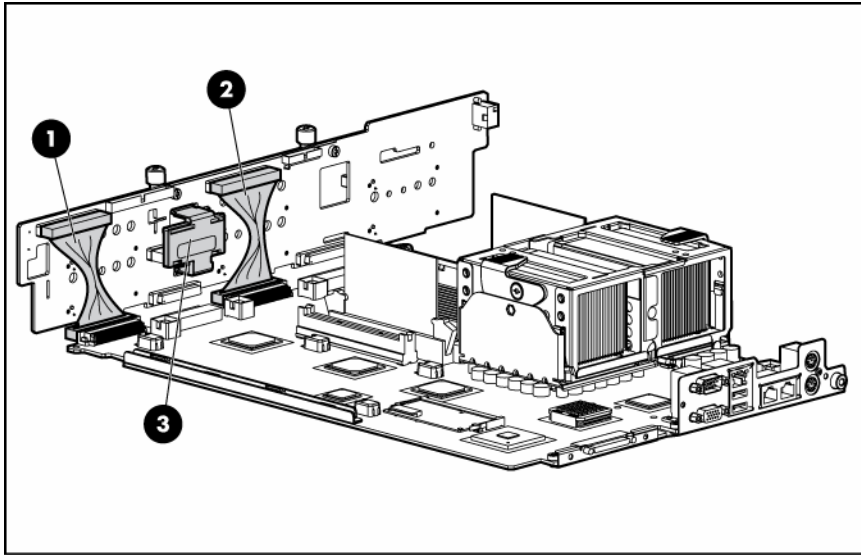

 **NOTE:** Optional SCSI terminator board and optional long SCSI cables are available in the SCSI Configuration Option Kit.

 **NOTE:** The short SCSI cables are identical.

Item	Component description	SCSI IDs managed
1	Short SCSI cable	0, 1
2	Short SCSI cable	2, 3, 4, 5
3	Optional terminator board	N/A

Refer to "Installing the SCSI terminator board (on page 63)" for SCSI terminator board installation procedures.

## PCI simplex SCSI cabling

In the PCI simplex cabling configuration, an optional PCI array controller controls up to six hard drives through one SCSI bus.

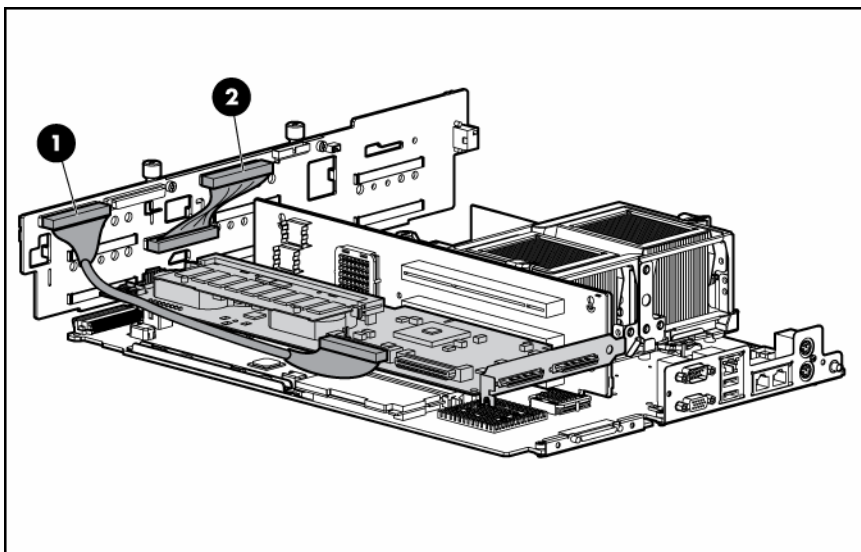



 **NOTE:** Optional SCSI terminator board and optional long SCSI cables are available in the SCSI Configuration Option Kit.

Item	Component description	SCSI IDs managed
1	Optional long SCSI cable	0, 1, 2, 3, 4, 5
2	Short SCSI cable used to jumper the two SCSI buses together	N/A

## PCI duplex SCSI cabling

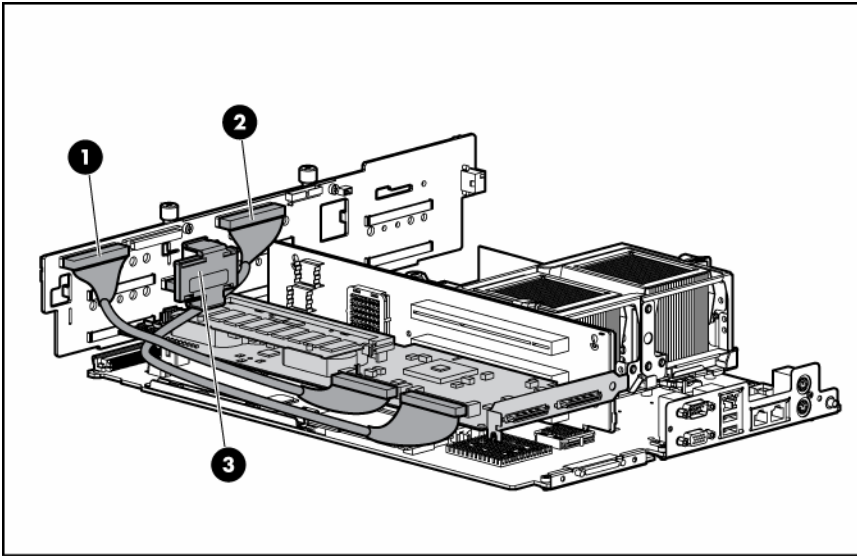
In the PCI duplex cabling configuration, an optional PCI array controller controls up to six hard drives through two SCSI buses: one bus with up to two drives and one bus with up to four drives.



 **NOTE:** Optional SCSI terminator board and optional long SCSI cables are available in the SCSI Configuration Option Kit.

Item	Component description	SCSI IDs managed
1	Optional long SCSI cable	0, 1
2	Optional long SCSI cable	2, 3, 4, 5
3	Optional terminator board	N/A

Refer to "Installing the SCSI terminator board (on page 63)" for SCSI terminator board installation procedures.

## Mixed duplex SCSI cabling

In the mixed duplex SCSI cabling configuration, an optional PCI array controller controls up to six hard drives through two SCSI buses: one bus with up to two drives and one bus with up to four drives. Two configuration options are available for mixed duplex SCSI cabling.

 **NOTE:** This specific cabling configuration does not support external VHDCI.

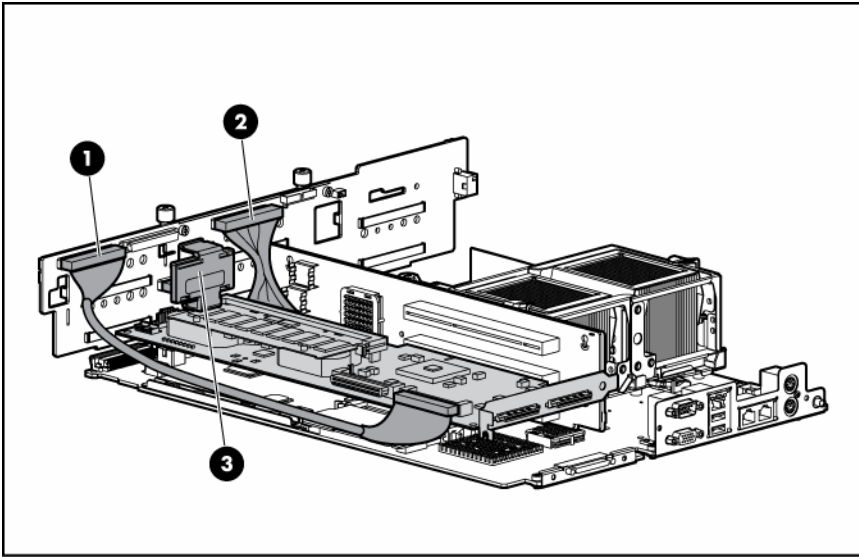

 **NOTE:** Optional SCSI terminator board and optional long SCSI cables are available in the SCSI Configuration Option Kit.

Item	Component description	SCSI IDs managed
1	Optional long SCSI cable	0, 1
2	Short SCSI cable	2, 3, 4, 5
3	Optional terminator board	N/A

 **NOTE:** This specific cabling configuration supports external VHDCI.

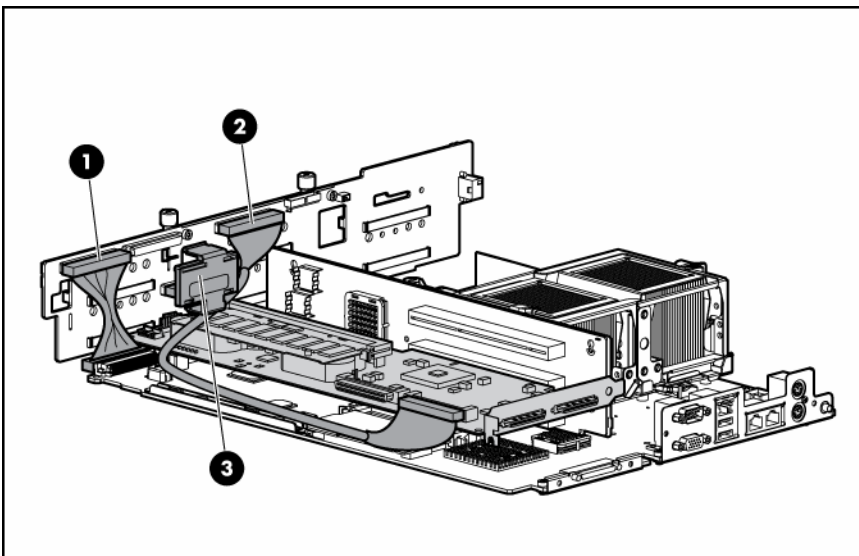

 **NOTE:** Optional SCSI terminator board and optional long SCSI cables are available in the SCSI Configuration Option Kit.

Item	Component description	SCSI IDs managed
1	Short SCSI cable	0, 1
2	Optional long SCSI cable	2, 3, 4, 5

Item	Component description	SCSI IDs managed
3	Optional terminator board	N/A

Refer to "Installing the SCSI Terminator Board (on page 63)" for SCSI terminator board installation procedures.

## Installing the SCSI terminator board

1. Power down the server (on page 20).
2. Extend or remove the server from the rack ("Extend the server from the rack" on page 19, "Remove the server from the rack" on page 20).
3. Remove the access panel ("Access panel" on page 22).
4. Remove the front fan bracket ("Front fan bracket" on page 25).

**IMPORTANT:** For this procedure, you do not need to remove the hot-plug fans from the front fan bracket. When reinstalling the front fan bracket, press the top of each fan to be sure it seats securely.

**NOTE:** For more information on preparing the server for installation or removal procedures, refer to the Documentation CD.

5. Install the SCSI terminator board.

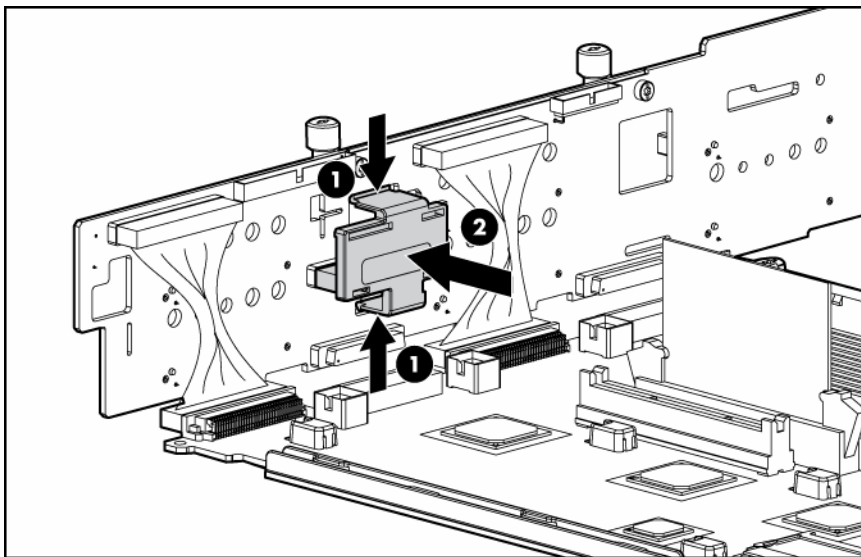

## Removing the SCSI terminator board

1. Power down the server (on page 20).
2. Extend or remove the server from the rack ("Extend the server from the rack" on page 19, "Remove the server from the rack" on page 20).
3. Remove the access panel ("Access panel" on page 22).
4. Remove the front fan bracket ("Front fan bracket" on page 25).

**IMPORTANT:** For this procedure, you do not need to remove the hot-plug fans from the front fan bracket. When reinstalling the front fan bracket, press the top of each fan to be sure it seats securely.

**NOTE:** For more information on preparing the server for installation or removal procedures, refer to the Documentation CD.



5. Remove the SCSI terminator board.

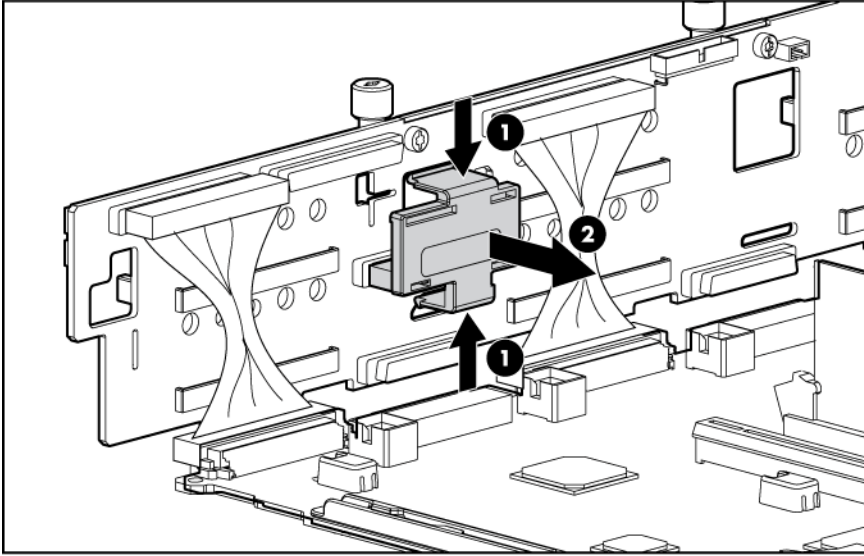

## USB cabling

The USB cable connects the front panel USB connector to the SCSI backplane.

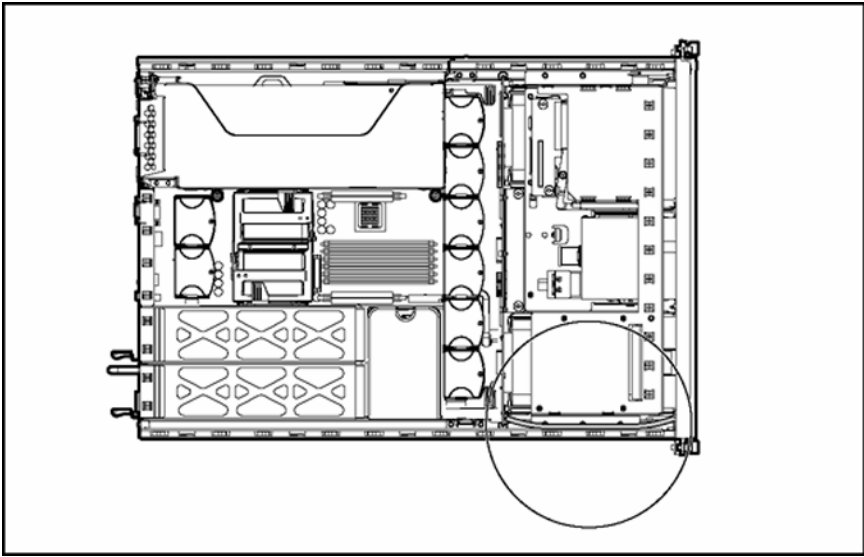



## DVD/CD-ROM drive cabling

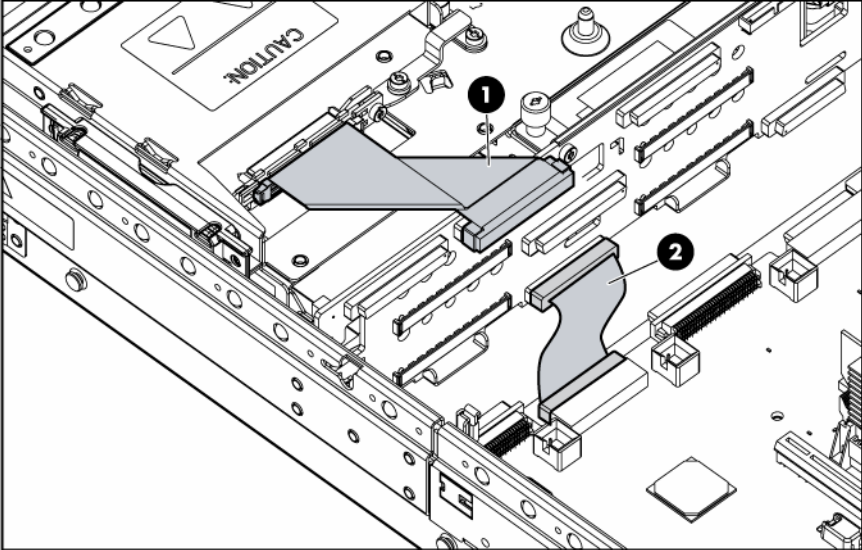

Item	Cable description
1	DVD/CD-ROM drive cable
2	DVD/CD-ROM drive system cable

## Diskette drive cabling

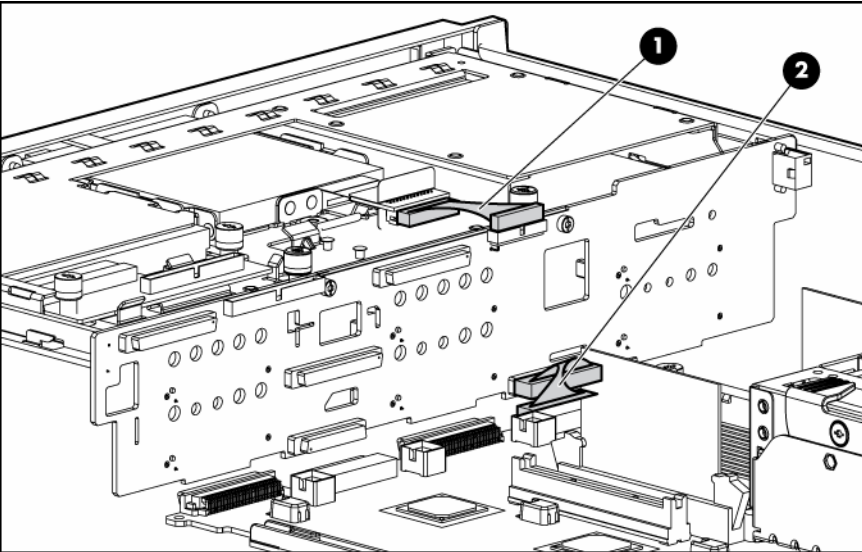

Item	Cable description
1	Diskette drive cable
2	Diskette drive system cable

## Power button/LED cabling

The power button/LED cable connects the power button/LED board to the SCSI backplane.

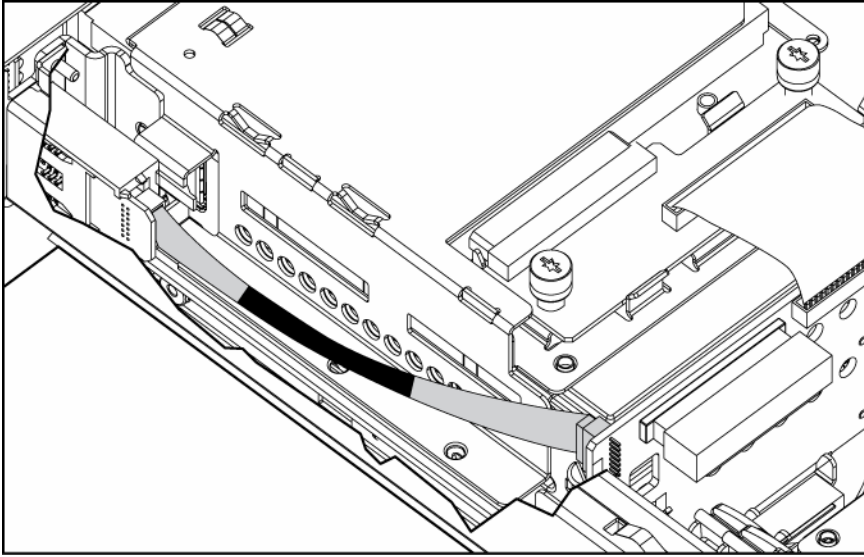

## Optional PCI Hot Plug backplane cabling

The server contains a PCI Hot Plug backplane that is part of the PCI Hot Plug option and provides hot-plug capability for two expansion slots. A ribbon cable connects the PCI Hot Plug backplane to the riser board.

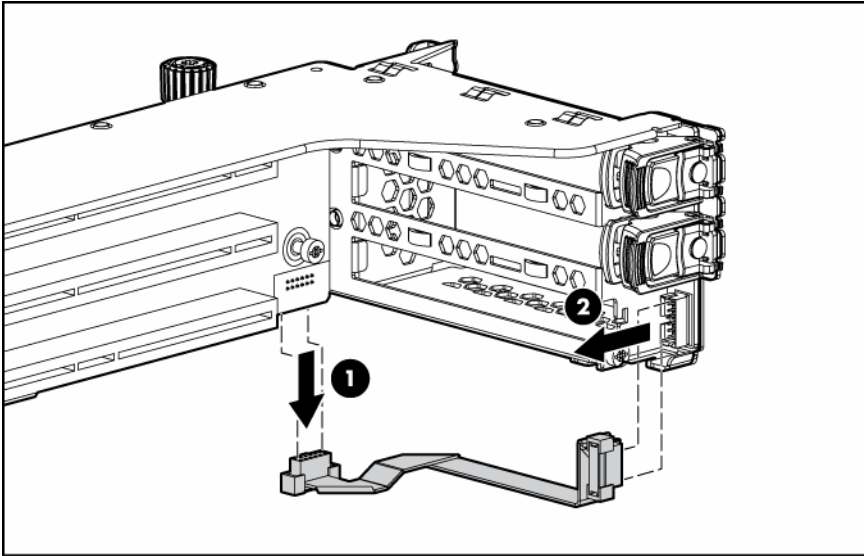

## RILOE II cabling

The 30-pin Remote Insight cable ships with the RILOE II cable kit. For more information, refer to the *Remote Insight Lights-Out Edition II User Guide* on the Documentation CD.

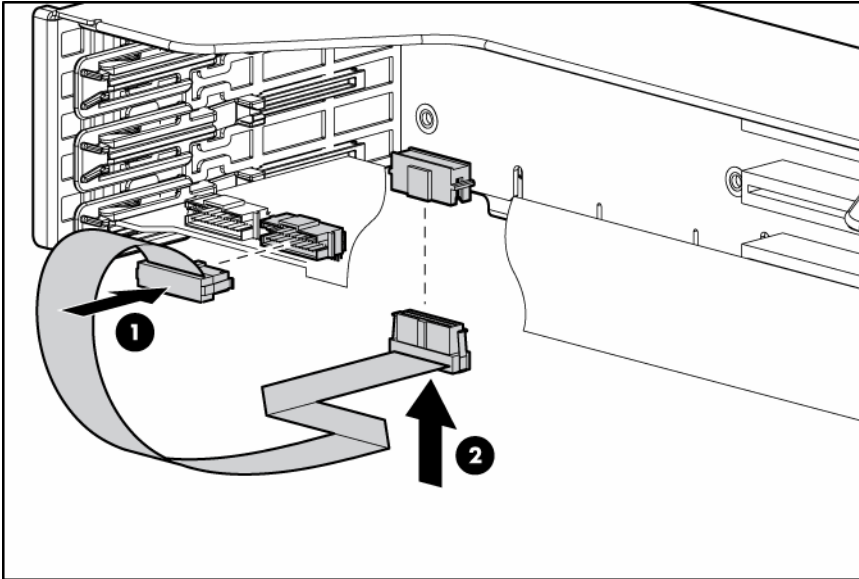

## Internal power cabling

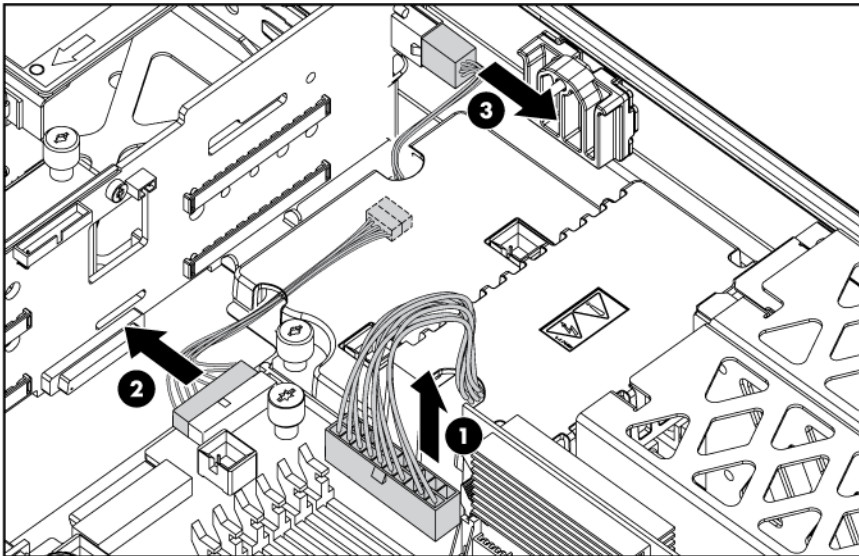

Item	Description
1	System power cable
2	Power supply signal cable
3	SCSI power cable

## External storage cabling

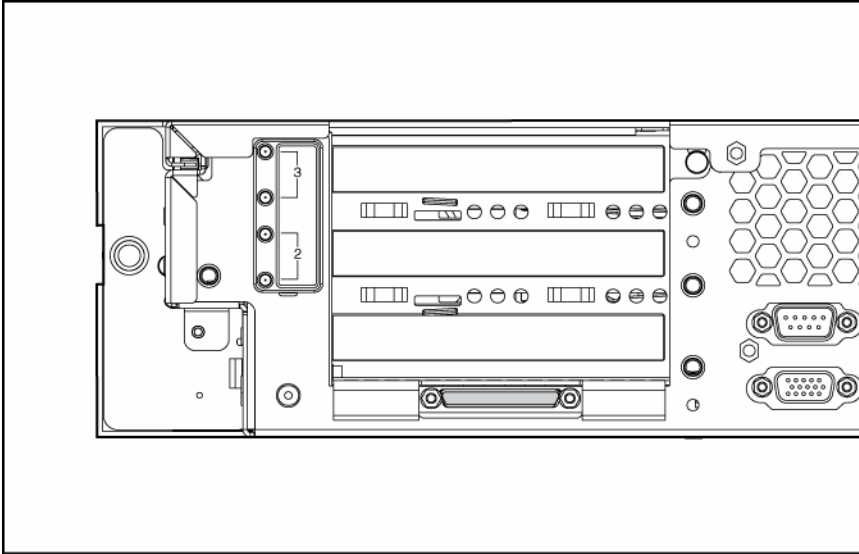

The external VHDCI SCSI connector (port 1) can only be used in the following SCSI configurations:

- Embedded simplex
- PCI simplex
- PCI duplex
- Mixed duplex (one of two configuration options)

For more information, refer to "Mixed duplex SCSI cabling ("PCI duplex SCSI cabling" on page 61)".

After cabling external storage options, use the following software utilities:

- RBSU, to configure new hardware in the system  
For more information, refer to "HP ROM-Based Setup Utility (on page 72)" or the *ROM-Based Setup Utility User Guide* on the Documentation CD.
- ORCA, to configure and manage drive arrays  
For more information, refer to the *Smart Array 6i Controller User Guide* on the Documentation CD.

For more information on external cabling, refer to the HP website (<http://www.hp.com/products/servers/platforms>).

---

# Diagnostic tools

## In this section

Troubleshooting resources .....	69
Array Diagnostic Utility .....	69
Automatic Server Recovery .....	69
HP Insight Diagnostics.....	70
Integrated Management Log .....	70
Survey Utility.....	70
HP Systems Insight Manager.....	71
Lights Out Manager technology .....	71
Option ROM Configuration for Arrays .....	71
HP ProLiant Essentials Rapid Deployment Pack.....	71
HP ROM-Based Setup Utility .....	72
SmartStart software .....	72

## Troubleshooting resources

The *HP ProLiant Servers Troubleshooting Guide* provides simple procedures for resolving common problems as well as a comprehensive course of action for fault isolation and identification, error message interpretation, issue resolution, and software maintenance.

To obtain the guide, refer to any of the following sources and then select the *HP ProLiant Servers Troubleshooting Guide*:

- The server-specific Documentation CD
- The Business Support Center on the HP website (<http://www.hp.com/support>). Navigate to the server technical support page. Under self-help resources, select **ProLiant Troubleshooting Guide**.
- The Technical Documentation website (<http://www.docs.hp.com>). Select **Enterprise Servers, Workstations and Systems Hardware**, and then the appropriate server.

## Array Diagnostic Utility

ADU is a tool that collects information about array controllers and generates a list of detected problems. ADU can be accessed from the SmartStart CD ("**SmartStart software**" on page 72) or downloaded from the HP website (<http://www.hp.com>).

## Automatic Server Recovery

ASR is a feature that causes the system to restart when a catastrophic operating system error occurs, such as a blue screen, ABEND, or panic. A system fail-safe timer, the ASR timer, starts when the System Management driver, also known as the Health Driver, is loaded. When the operating system is functioning properly, the system periodically resets the timer. However, when the operating system fails, the timer expires and restarts the server.

ASR increases server availability by restarting the server within a specified time after a system hang or shutdown. At the same time, the HP SIM console notifies you by sending a message to a designated pager number that ASR has restarted the system. You can disable ASR from the HP SIM console or through RBSU.

## HP Insight Diagnostics

HP Insight Diagnostics is a proactive server management tool, available in both offline and online versions, that provides diagnostics and troubleshooting capabilities to assist IT administrators who verify server installations, troubleshoot problems, and perform repair validation.

HP Insight Diagnostics Offline Edition performs various in-depth system and component testing while the OS is not running. To run this utility, launch the SmartStart CD.

HP Insight Diagnostics Online Edition is a web-based application that captures system configuration and other related data needed for effective server management. Available in Microsoft® Windows® and Linux versions, the utility helps to ensure proper system operation.

For more information or to download the utility, refer to the HP website (<http://www.hp.com/servers/diags>).

## Integrated Management Log

The IML records hundreds of events and stores them in an easy-to-view form. The IML timestamps each event with 1-minute granularity.

You can view recorded events in the IML in several ways, including the following:

- From within HP SIM ("HP Systems Insight Manager" on page 71)
- From within Survey Utility (on page 70)
- From within operating system-specific IML viewers
  - For NetWare: IML Viewer
  - For Windows®: IML Viewer
  - For Linux: IML Viewer Application
- From within the RILOE user interface
- From within HP Insight Diagnostics (on page 70)

For more information, refer to the Management CD in the HP ProLiant Essentials Foundation Pack.

## Survey Utility

Survey Utility, a feature within HP Insight Diagnostics (on page 70), gathers critical hardware and software information on ProLiant servers.

This utility supports operating systems that may not be supported by the server. For operating systems supported by the server, refer to the HP website (<http://www.hp.com/go/supportos>).

If a significant change occurs between data-gathering intervals, the Survey Utility marks the previous information and overwrites the Survey text files to reflect the latest changes in the configuration.

Survey Utility is installed with every SmartStart-assisted installation or can be installed through the HP PSP.



**NOTE:** SmartStart version 7.5 and later provides the memory spare part numbers for the server.

# HP Systems Insight Manager

HP SIM is a web-based application that allows system administrators to accomplish normal administrative tasks from any remote location, using a web browser. HP SIM provides device management capabilities that consolidate and integrate management data from HP and third-party devices.



**IMPORTANT:** You must install and use HP SIM to benefit from the Pre-Failure Warranty for processors, SAS and SCSI hard drives, and memory modules.

For additional information, refer to the Management CD in the HP ProLiant Essentials Foundation Pack or the HP SIM website (<http://www.hp.com/go/hpsim>).

## Lights Out Manager technology

The RILOE subsystem is a standard component of selected ProLiant servers that provides server health and remote server manageability. The RILOE subsystem includes an intelligent microprocessor, secure memory, and a dedicated network interface. This design makes RILOE independent of the host server and its operating system. The RILOE subsystem provides remote access to any authorized network client, sends alerts, and provides other server management functions.

Using RILOE, you can:

- Remotely power up, power down, or reboot the host server.
- Send alerts from RILOE regardless of the state of the host server.
- Access advanced troubleshooting features through the RILOE interface.
- Diagnose RILOE using HP SIM through a web browser and SNMP alerting.

For more information about RILOE features, refer to the RILOE documentation on the Documentation CD or on the HP website (<http://www.hp.com/servers/lights-out>).

## Option ROM Configuration for Arrays

Before installing an operating system, you can use the ORCA utility to create the first logical drive, assign RAID levels, and establish online spare configurations.

The utility also provides support for the following functions:

- Reconfiguring one or more logical drives
- Viewing the current logical drive configuration
- Deleting a logical drive configuration
- Setting the controller to be the boot controller

If you do not use the utility, ORCA will default to the standard configuration.

For more information regarding array controller configuration, refer to the controller user guide.

For more information regarding the default configurations that ORCA uses, refer to the *HP ROM-Based Setup Utility User Guide* on the Documentation CD.

## HP ProLiant Essentials Rapid Deployment Pack

The RDP software is the preferred method for rapid, high-volume server deployments. The RDP software integrates two powerful products: Altiris Deployment Solution and the HP ProLiant Integration Module.



The intuitive graphical user interface of the Altiris Deployment Solution console provides simplified point-and-click and drag-and-drop operations that enable you to deploy target servers, including server blades, remotely. It enables you to perform imaging or scripting functions and maintain software images.

For more information about the RDP, refer to the HP ProLiant Essentials Rapid Deployment Pack CD or refer to the HP website (<http://www.hp.com/servers/rdp>).

## HP ROM-Based Setup Utility

RBSU, an embedded configuration utility, performs a wide range of configuration activities that may include:

- Configuring system devices and installed options
- Displaying system information
- Selecting the primary boot controller
- Configuring memory options
- Language selection

For more information on RBSU, refer to the *HP ROM-Based Setup Utility User Guide* on the Documentation CD or the HP website (<http://www.hp.com/servers/smartstart>).

## SmartStart software

SmartStart is a collection of software that optimizes single-server setup, providing a simple and consistent way to deploy server configuration. SmartStart has been tested on many ProLiant server products, resulting in proven, reliable configurations.

SmartStart assists the deployment process by performing a wide range of configuration activities, including:

- Configuring hardware using embedded configuration utilities, such as RBSU and ORCA
- Preparing the system for installing "off-the-shelf" versions of leading operating system software
- Installing optimized server drivers, management agents, and utilities automatically with every assisted installation
- Testing server hardware using the Insight Diagnostics Utility ("[HP Insight Diagnostics](#)" on page 70)
- Installing software drivers directly from the CD. With systems that have internet connection, the SmartStart Autorun Menu provides access to a complete list of ProLiant system software.
- Enabling access to the Array Configuration Utility, Array Diagnostic Utility (on page 69), and Erase Utility

SmartStart is included in the HP ProLiant Essentials Foundation Pack. For more information about SmartStart software, refer to the HP ProLiant Essentials Foundation Pack or the HP website (<http://www.hp.com/servers/smartstart>).

## ROMPaq utility

Flash ROM enables you to upgrade the firmware (BIOS) with system or option ROMPaq utilities. To upgrade the BIOS, insert a ROMPaq diskette into the diskette drive and boot the system.

The ROMPaq utility checks the system and provides a choice (if more than one exists) of available ROM revisions. This procedure is the same for both system and option ROMPaq utilities.

For more information about the ROMPaq utility, refer to the HP website (<http://www.hp.com/servers/manage>).



## System Online ROM flash component utility

The Online ROM Flash Component Utility enables system administrators to efficiently upgrade system or controller ROM images across a wide range of servers and array controllers. This tool has the following features:

- Works offline and online
- Supports Microsoft® Windows NT®, Windows® 2000, Windows Server™ 2003, Novell Netware, and Linux operating systems



**IMPORTANT:** This utility supports operating systems that may not be supported by the server. For operating systems supported by the server, refer to the HP website (<http://www.hp.com/go/supportos>).

- Integrates with other software maintenance, deployment, and operating system tools
- Automatically checks for hardware, firmware, and operating system dependencies, and installs only the correct ROM upgrades required by each target server

To download the tool and for more information, refer to the HP website (<http://h18000.www1.hp.com/support/files/index.html>).

---

# Component identification

## In this section

Front panel components .....	75
Front panel LEDs and buttons .....	76
Rear panel components .....	77
Rear panel LEDs and buttons .....	78
System board components .....	79
SCSI backplane components .....	81
SAS backplane components .....	82
System board LEDs .....	82
System LEDs and internal health LED combinations .....	83
SCSI backplane LEDs .....	85
Hot-plug SCSI hard drive LEDs .....	85
Hot-plug SCSI hard drive LED combinations .....	86
Hot-plug SAS hard drive LEDs .....	87
Hot-plug SAS hard drive LED combinations .....	87
PCI Hot Plug LED status combinations .....	88
PCI riser cage LED .....	89
Remote management connector .....	89
Internal PCI Hot Plug LEDs and button .....	90
Identifying hot-plug fans .....	90
Hot-plug fan LED .....	91
Power converter module LED .....	92
Battery-backed write cache LEDs .....	92
Battery-backed write cache LED statuses .....	93

# Front panel components

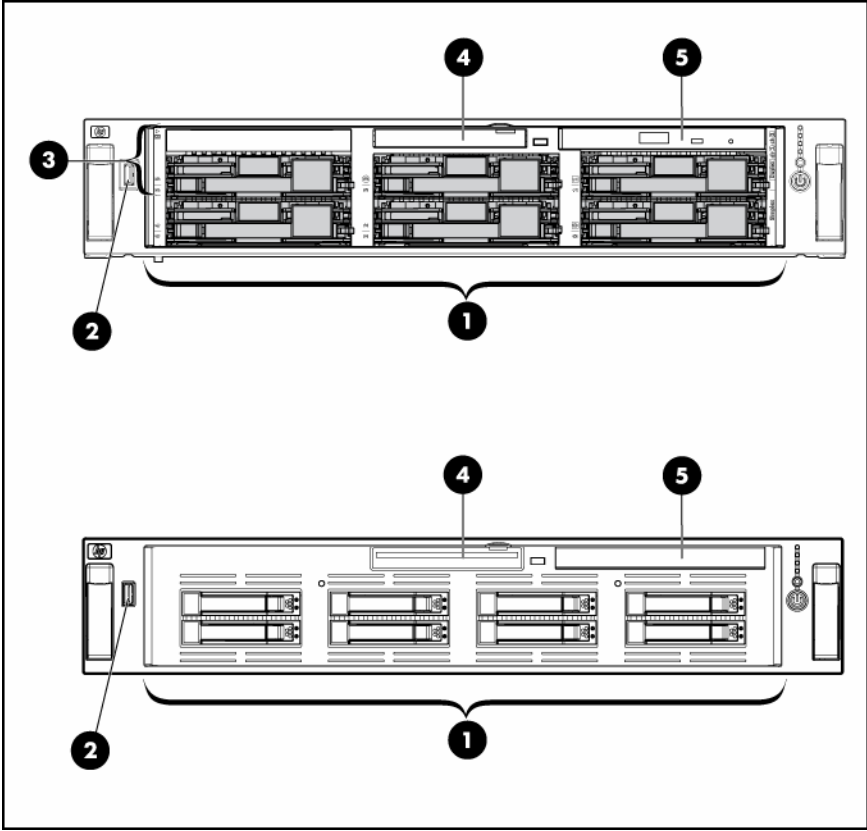

Item	SCSI model (top)	SAS model (bottom)
1	Hard drive bays	Hard drive bays
2	USB port	USB port
3	Bay for tape drive or hard drive with tape drive blank	—
4	Diskette drive bay	Diskette drive bay
5	DVD/CD-ROM drive	DVD/CD-ROM drive

# Front panel LEDs and buttons

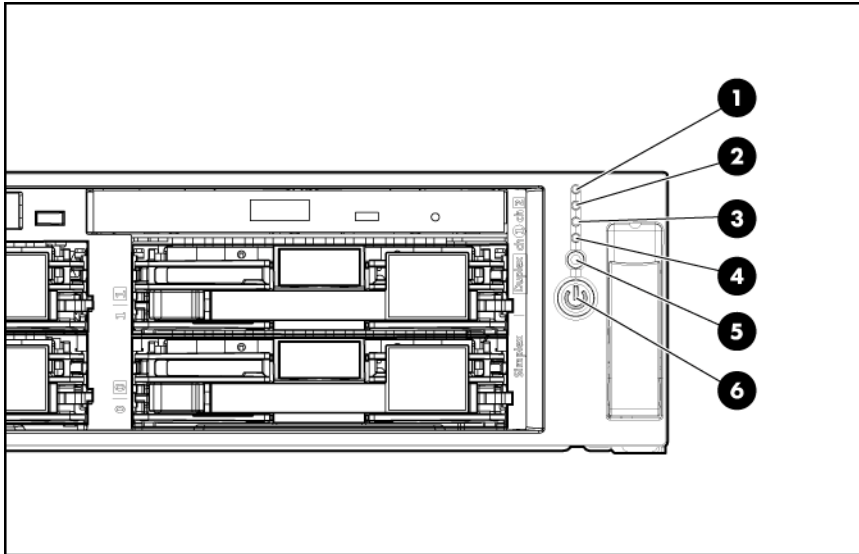

Item	Description	Status
1	Internal health LED	Green = Normal Amber = System degraded. Refer to system board LEDs to identify component in degraded state. Red = System critical. Refer to system board LEDs to identify component in critical state.
2	External health LED (power supply)	Green = Normal Amber = Power redundancy failure Red = Critical power supply failure
3	NIC 1 link/activity LED	Green = Network link Flashing = Network link and activity Off = No link to network. If power is off, view the rear panel RJ-45 LEDs for status.
4	NIC 2 link/activity LED	Green = Network link Flashing = Network link and activity Off = No link to network. If power is off, view the rear panel RJ-45 LEDs for status.
5	UID LED button	Blue = Activated Flashing = System being remotely managed Off = Deactivated
6	Power On/Standby button/system power LED	Green = System on Amber = System shut down, but power still applied Off = Power cord not attached or power supply failure

## Rear panel components

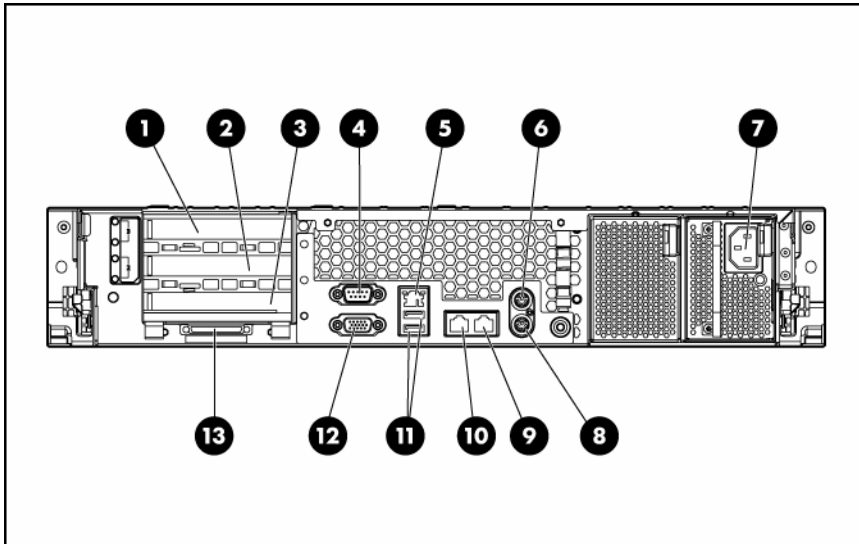

Item	Description	Color
1	<ul style="list-style-type: none"> <li>Hot-plug or non-hot-plug PCI-X expansion slot 3, 64 bit/100 MHz, bus B</li> <li>PCI Express x4 slot 2, bus B*</li> </ul>	N/A
2	<ul style="list-style-type: none"> <li>Hot-plug or non-hot-plug PCI-X expansion slot 2, 64 bit/100 MHz, bus B</li> <li>PCI Express x4 slot 1, bus A*</li> </ul>	N/A
3	Non-hot-plug PCI-X expansion slot 1, 64 bit/133 MHz, bus A	N/A
4	Serial connector	Teal
5	iLO connector	N/A
6	Mouse connector	Green
7	Power cord connector	N/A
8	Keyboard connector	Purple
9	NIC 1 connector	N/A
10	NIC 2 connector	N/A
11	USB connectors	Black
12	Video connector	Blue
13	VHD CI SCSI connector (port 1)**	N/A

\* x8 PCI Express cards are supported on the SCSI models and will run at x4 speeds. SAS models do not support PCI Express cards.

\*\*This feature applies only to SCSI models.

## Rear panel LEDs and buttons

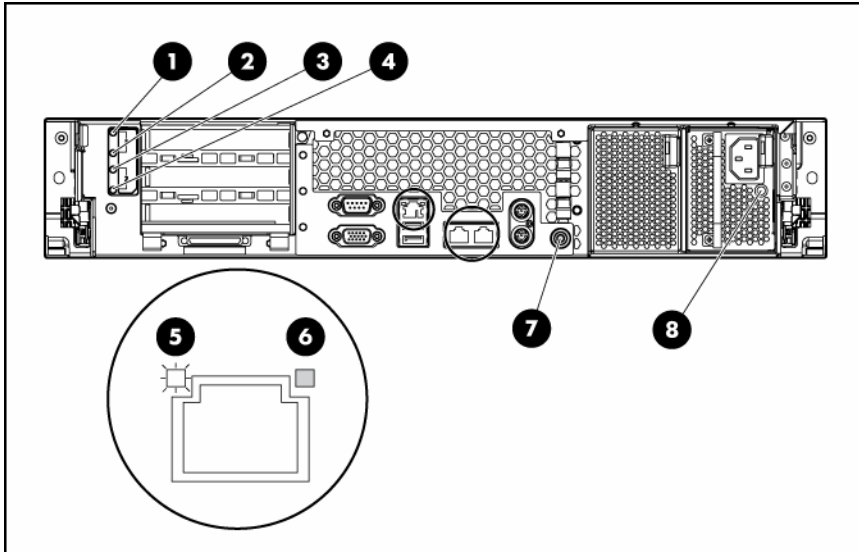

Item	Description	LED Color	Status
1	PCI Hot Plug fault LED (slot 3)*	Amber	On = Expansion board failed Off = Normal
2	PCI Hot Plug power LED (slot 3)*	Green	On = Power is applied to the slot Flashing = Power is cycling Off = Power is not applied to the slot
3	PCI Hot Plug fault LED (slot 2)*	Amber	On = Expansion board failed Off = Normal
4	PCI Hot Plug power LED (slot 2)*	Green	On = Power is applied to the slot Flashing = Power is cycling Off = Power is not applied to the slot
5	RJ-45 activity LED	Green	On or flashing = Network activity Off = No network activity
6	RJ-45 link LED	Green	On = Linked to network Off = Not linked to network
7	UID LED button	Blue	On = Activated Flashing = System remotely managed Off = Deactivated
8	Power supply LED	Green	On = Power turned on and power supply functioning properly Off = One or more of the following conditions exists: <ul style="list-style-type: none"> <li>• AC power unavailable</li> <li>• Power supply failed</li> <li>• Power supply in standby mode</li> <li>• Power supply exceeded current limit</li> </ul>

\* This LED is only available when using the hot-plug expansion cage option.

# System board components

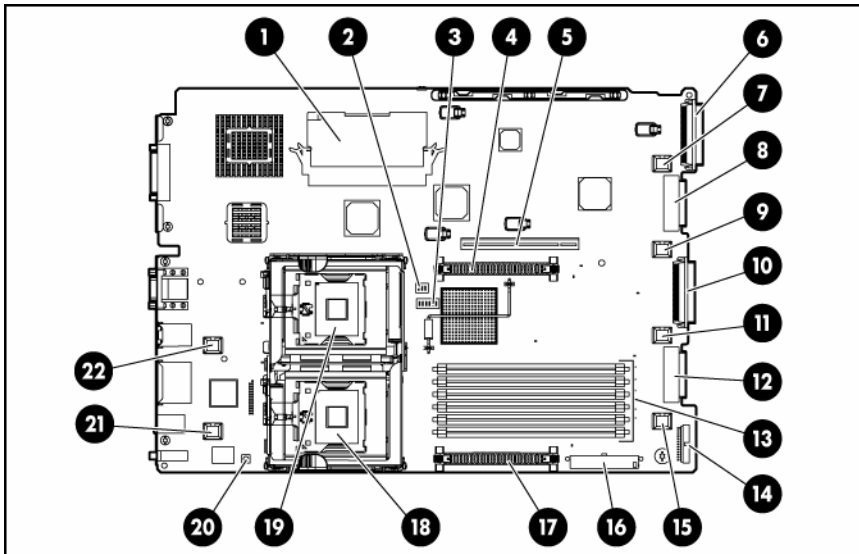

Item	Description	Item	Description
1	Smart Array 6i Cache Module Option*	12	Diskette drive system connector
2	Chassis ID switch	13	DIMM slots (1-6)
3	System maintenance switch	14	Power supply signal connector
4	PPM slot 2	15	Fan 6 connector
5	PCI riser cage connector	16	System power connector
6	SCSI connector (port 2)*	17	PPM slot 1
7	Fan 3 connector	18	Processor socket 1
8	DVD/CD-ROM drive system connector	19	Processor socket 2
9	Fan 4 connector	20	NMI switch
10	SCSI connector (port 1)*	21	Fan 2 connector
11	Fan 5 connector	22	Fan 1 connector

\*This feature applies only to SCSI models.

## System maintenance switch

Position	Default	Function
S1	Off	Off = iLO security is enabled. On = iLO security is disabled.
S2	Off	Off = System configuration can be changed. On = System configuration is locked.
S3	Off	Reserved
S4	Off	Off = Booting from diskette is controlled by RBSU. On = Booting from diskette is enabled and RBSU is overridden.

Position	Default	Function
S5	Off	Off = No function On = Clears power-on password and administrator password.
S6	Off	Off = No function On = Clear NVRAM.

When the system maintenance switch position 6 is set to the On position, the system is prepared to erase all system configuration settings from both CMOS and NVRAM.

**⚠ CAUTION:** Clearing CMOS and/or NVRAM deletes configuration information. Be sure to properly configure the server or data loss could occur.

## NMI switch

The NMI switch allows administrators to perform a memory dump before performing a hard reset. Crash dump analysis is an essential part of eliminating reliability problems, such as hangs or crashes in operating systems, device drivers, and applications. Many crashes freeze a system, requiring you to do a hard reset. Resetting the system erases any information that would support root cause analysis.

Systems running Microsoft® Windows® operating systems experience a blue screen trap when the operating system crashes. When this happens, Microsoft® recommends that system administrators perform an NMI event by pressing a dump switch. The NMI event enables a hung system to become responsive again.

## Chassis ID switch

The chassis ID switch on the system board is reserved for use by authorized technicians only. Do not modify the switch setting.

## DIMM slots

DIMM slots are numbered sequentially (1 through 6) and the paired banks are identified by the letters A, B, and C.

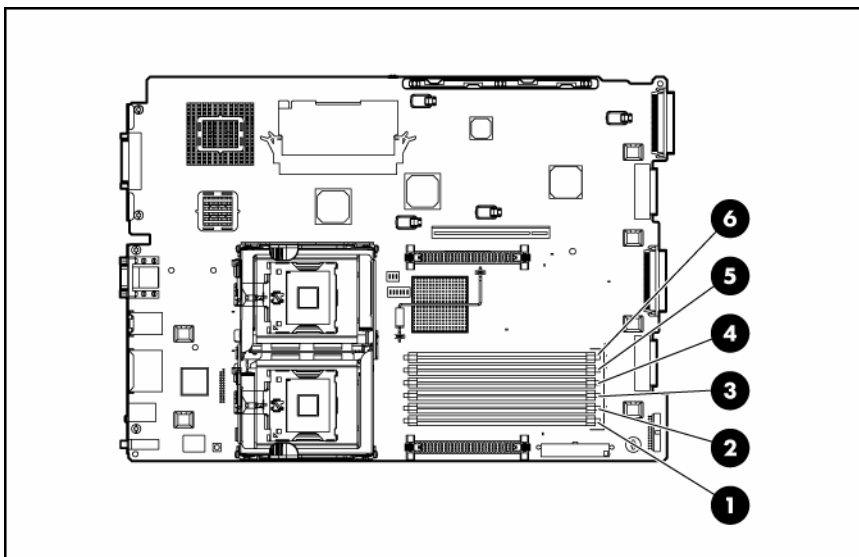



Item	Description
1	DIMM slot 1A
2	DIMM slot 2A
3	DIMM slot 3B
4	DIMM slot 4B
5	DIMM slot 5C
6	DIMM slot 6C

## SCSI backplane components

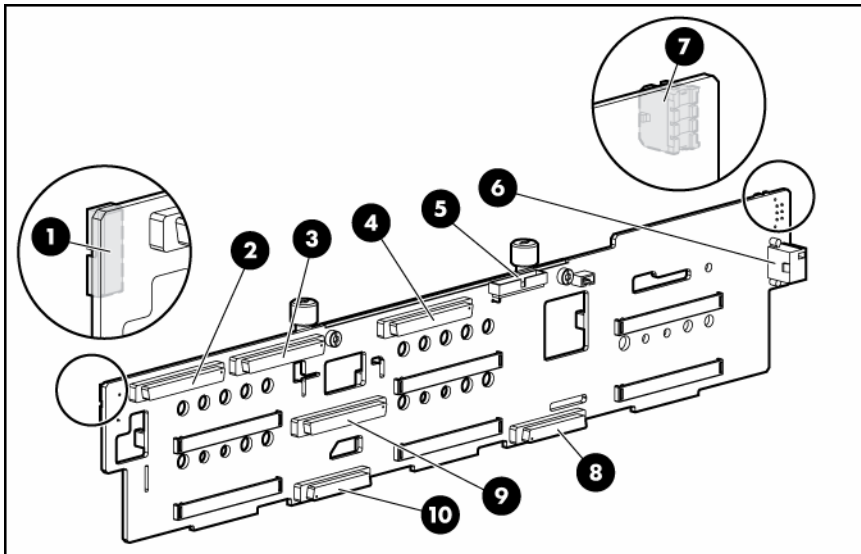

Item	Description
1	Power button/LED connector
2	SCSI connector (port 2)
3	DVD/CD-ROM drive connector
4	SCSI connector (port 1)
5	Diskette drive connector
6	Power connector
7	USB connector
8	Diskette drive system connector
9	SCSI connector (used with a jumper cable in simplex mode or terminator board in duplex mode)
10	DVD/CD-ROM drive system connector

## SAS backplane components

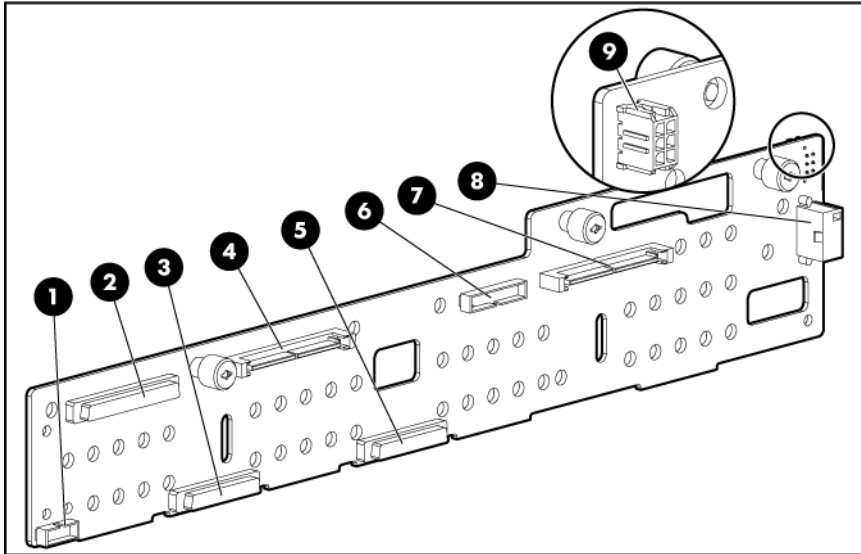

Item	Description
1	Power button/LED connector
2	DVD/CD-ROM drive connector
3	DVD/CD-ROM drive system connector
4	SAS connector
5	Diskette drive system connector
6	Diskette drive connector
7	SAS connector
8	Power connector
9	USB connector

## System board LEDs

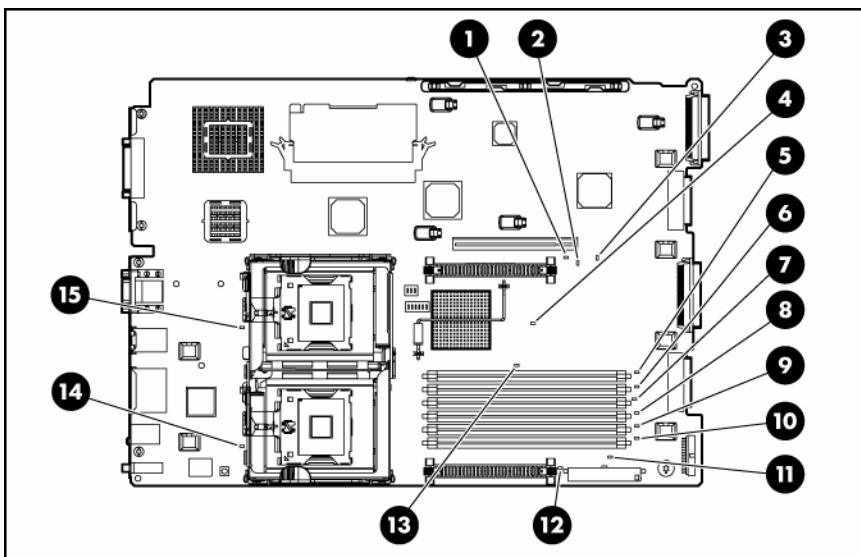

Item	LED description	Status
1	PPM 2 failure	Amber = PPM failed Off = Normal
2	Overtemperature	Amber = Cautionary or critical temperature level detected Off = Temperature OK
3	Riser interlock	Amber = PCI riser cage not seated Off = PCI riser cage is seated
4	Fan failure LED	Off = Fan is not powered Green = Normal Amber = Failure
5	DIMM 6C failure	Amber = Memory failed* Off = Normal
6	DIMM 5C failure	Amber = Memory failed* Off = Normal
7	DIMM 4B failure	Amber = Memory failed* Off = Normal
8	DIMM 3B failure	Amber = Memory failed* Off = Normal
9	DIMM 2A failure	Amber = Memory failed* Off = Normal
10	DIMM 1A failure	Amber = Memory failed* Off = Normal
11	Online spare memory	Amber = Failover, online spare memory in use Green = Enabled, but not in use Off = Disabled
12	PPM 1 failure	Amber = PPM failed Off = Normal
13	iLO diagnostic LEDs	Refer to the <i>HP Integrated Lights-Out User Guide</i> on the Documentation CD.
14	Processor 1 failure	Amber = Processor failed Off = Normal
15	Processor 2 failure	Amber = Processor failed Off = Normal

\*If all DIMM failure LEDs are lit, the memory configuration is invalid. Refer to "DIMM Configuration Requirements" for proper memory configuration.

## System LEDs and internal health LED combinations

When the internal health LED on the front panel illuminates either amber or red, the server is experiencing a health event. Combinations of illuminated system LEDs and the internal health LED indicate system status.

The front panel health LEDs indicate only the current hardware status. In some situations, HP SIM may report server status differently than the health LEDs because the software tracks more system attributes.

System LED and color	Internal health LED color	Status
Processor failure, socket X (amber)	Red	One or more of the following conditions may exist: <ul style="list-style-type: none"> <li>• Processor in socket X has failed.</li> <li>• Processor X is not installed in the socket.</li> <li>• Processor X is unsupported.</li> <li>• ROM detects a failed processor during POST.</li> </ul>
	Amber	Processor in socket X is in a pre-failure condition.
PPM failure, slot X (amber)	Red	<ul style="list-style-type: none"> <li>• PPM in slot X has failed.</li> <li>• PPM is not installed in slot X, but the corresponding processor is installed.</li> </ul>
DIMM failure, slot X (amber)	Red	<ul style="list-style-type: none"> <li>• DIMM in slot X has failed.</li> </ul>
	Amber	<ul style="list-style-type: none"> <li>• DIMM in slot X is in a pre-failure condition.</li> </ul>
DIMM failure, all slots in one bank (amber)	Red	No valid or usable memory is installed in the system.
Overtemperature (amber)	Red	<ul style="list-style-type: none"> <li>• The Health Driver has detected a cautionary temperature level.</li> <li>• The server has detected a hardware critical temperature level.</li> </ul>
Riser interlock (amber)	Red	PCI riser cage is not seated.
Online spare memory (amber)	Amber	Bank X failed over to the online spare memory bank.
Power converter module (amber)	Red	Power converter module has failed.
Fan (amber)	Amber	Redundant fan has failed.
	Red	The minimum fan requirements are not being met. One or more fans have failed or are missing.
SCSI configuration error (amber)*	Red	SCSI cabling or terminator configuration is incorrect for SCSI backplane.

\*This feature applies only to SCSI models.

# SCSI backplane LEDs

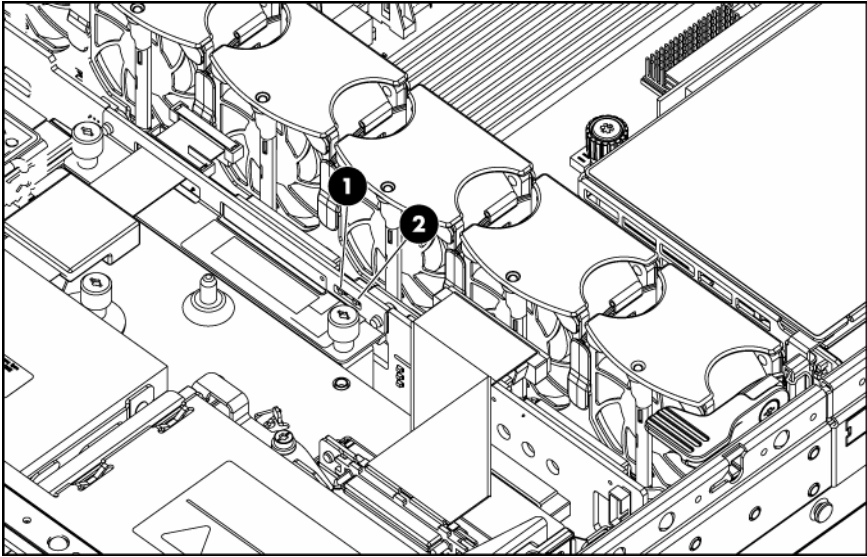

Item	LED description	Status
1	SCSI configuration	On = Simplex Off = Duplex
2	SCSI configuration error	On = SCSI cabling or terminator configuration is incorrect Off = SCSI cabling or terminator configuration is correct

# Hot-plug SCSI hard drive LEDs

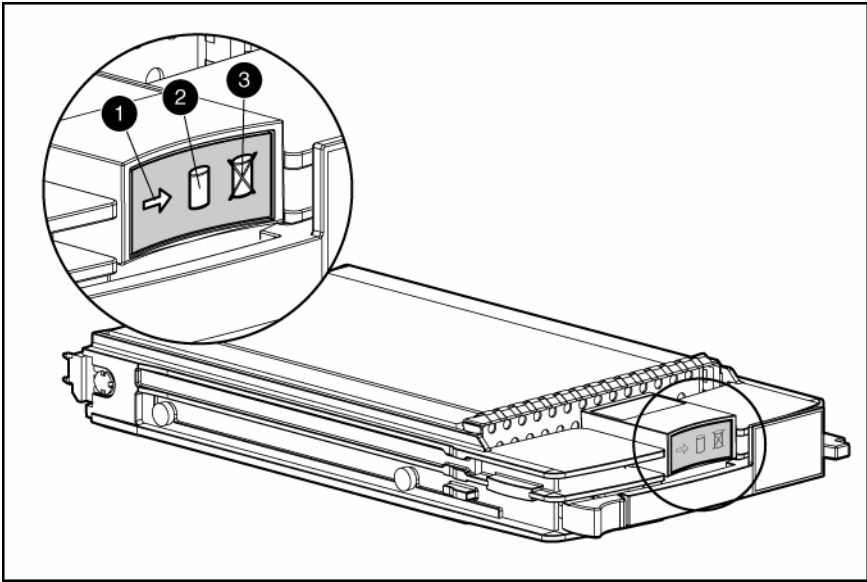

Item	LED description	Status
1	Activity status	On = Drive activity Flashing = High activity on the drive or drive is being configured as part of an array. Off = No drive activity
2	Online status	On = Drive is part of an array and is currently working. Flashing = Drive is actively online. Off = Drive is offline.
3	Fault status	On = Drive failure Flashing = Fault-process activity Off = No fault-process activity

## Hot-plug SCSI hard drive LED combinations

Activity LED (1)	Online LED (2)	Fault LED (3)	Interpretation
On, off, or flashing	On or off	Flashing	A predictive failure alert has been received for this drive. Replace the drive as soon as possible.
On, off, or flashing	On	Off	The drive is online and is configured as part of an array. If the array is configured for fault tolerance and all other drives in the array are online, and a predictive failure alert is received or a drive capacity upgrade is in progress, you may replace the drive online.
On or flashing	Flashing	Off	<b>Do not remove the drive. Removing a drive may terminate the current operation and cause data loss.</b> The drive is rebuilding or undergoing capacity expansion.
On	Off	Off	<b>Do not remove the drive.</b> The drive is being accessed, but (1) it is not configured as part of an array; (2) it is a replacement drive and rebuild has not yet started; or (3) it is spinning up during the POST sequence.
Flashing	Flashing	Flashing	<b>Do not remove the drive. Removing a drive may cause data loss in non-fault-tolerant configurations.</b> One or more of the following conditions may exist: <ul style="list-style-type: none"> <li>• The drive is part of an array being selected by an array configuration utility</li> <li>• Drive Identification has been selected in HP SIM</li> <li>• The drive firmware is being updated</li> </ul>
Off	Off	On	The drive has been placed offline due to hard disk drive failure or subsystem communication failure. You may need to replace the drive.

Activity LED (1)	Online LED (2)	Fault LED (3)	Interpretation
Off	Off	Off	<p>One or more of the following conditions may exist:</p> <ul style="list-style-type: none"> <li>The drive is not configured as part of an array</li> <li>The drive is configured as part of an array, but it is a replacement drive that is not being accessed or being rebuilt yet</li> <li>The drive is configured as an online spare</li> </ul> <p>If the drive is connected to an array controller, you may replace the drive online.</p>

## Hot-plug SAS hard drive LEDs

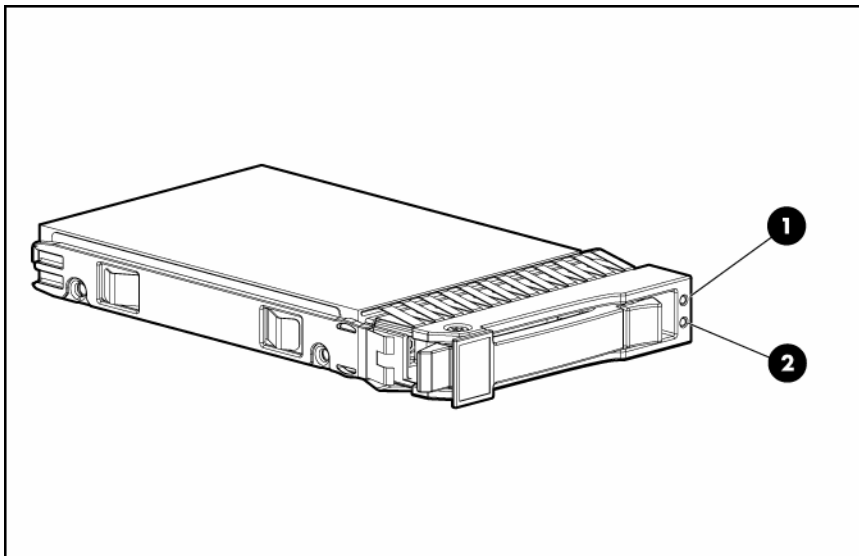

Item	Description
1	Fault/UID LED (amber/blue)
2	Online LED (green)

## Hot-plug SAS hard drive LED combinations

Online/activity LED (green)	Fault/UID LED (amber/blue)	Interpretation
On, off, or flashing	Alternating amber and blue	The drive has failed, or a predictive failure alert has been received for this drive; it also has been selected by a management application.
On, off, or flashing	Steadily blue	The drive is operating normally, and it has been selected by a management application.
On	Amber, flashing regularly (1 Hz)	A predictive failure alert has been received for this drive. Replace the drive as soon as possible.
On	Off	The drive is online, but it is not active currently.

Online/activity LED (green)	Fault/UID LED (amber/blue)	Interpretation
Flashing regularly (1 Hz)	Amber, flashing regularly (1 Hz)	<b>Do not remove the drive. Removing a drive may terminate the current operation and cause data loss.</b> The drive is part of an array that is undergoing capacity expansion or stripe migration, but a predictive failure alert has been received for this drive. To minimize the risk of data loss, do not replace the drive until the expansion or migration is complete.
Flashing regularly (1 Hz)	Off	<b>Do not remove the drive. Removing a drive may terminate the current operation and cause data loss.</b> The drive is rebuilding, or it is part of an array that is undergoing capacity expansion or stripe migration.
Flashing irregularly	Amber, flashing regularly (1 Hz)	The drive is active, but a predictive failure alert has been received for this drive. Replace the drive as soon as possible.
Flashing irregularly	Off	The drive is active, and it is operating normally.
Off	Steadily amber	A critical fault condition has been identified for this drive, and the controller has placed it offline. Replace the drive as soon as possible.
Off	Amber, flashing regularly (1 Hz)	A predictive failure alert has been received for this drive. Replace the drive as soon as possible.
Off	Off	The drive is offline, a spare, or not configured as part of an array.

## PCI Hot Plug LED status combinations

Power LED (green)	Fault LED (amber)	OK to open?	Slot status
On	Off	No	The power to the slot is on and the slot is functioning normally. <b>Do NOT open the slot release lever.</b>
On	On	No	The power to the slot is on, but the slot needs attention for a possible problem with the slot, board, or driver. <b>DO NOT open the slot release lever.</b> Examine the logs and HP SIM. If the expansion board is faulty, remove or replace the board.
Flashing	On or off	No	The power to the slot is being turned off or on, which may take several seconds. <b>DO NOT open the slot release lever.</b> To cancel the operation, press the PCI Hot Plug button.
Off	On	Yes	The power to the slot is off, but the slot needs attention for a possible problem with the slot, board, or driver.
Off	Off	Yes	The power to the slot is off.



## PCI riser cage LED

**CAUTION:** To prevent damage to the server or expansion boards, power down the server and remove all AC power cords before removing or installing the PCI riser cage.

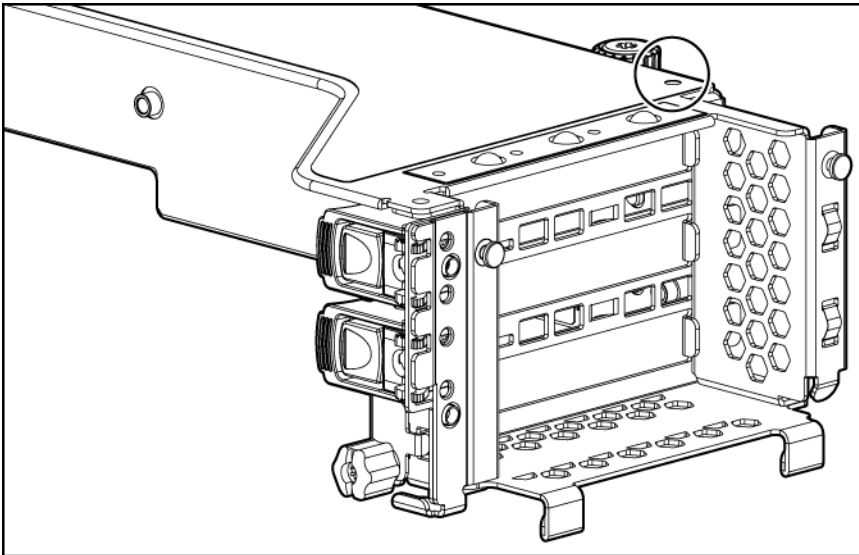

Status
On = AC power connected
Off = AC power disconnected

## Remote management connector

The 30-pin remote management connector, located on the PCI riser cage, is used to cable the Remote Insight Lights-Out Edition II option. For more information, refer to "RILOE II cabling (on page 58)" or the *Remote Insight Lights-Out Edition II User Guide* on the Documentation CD.

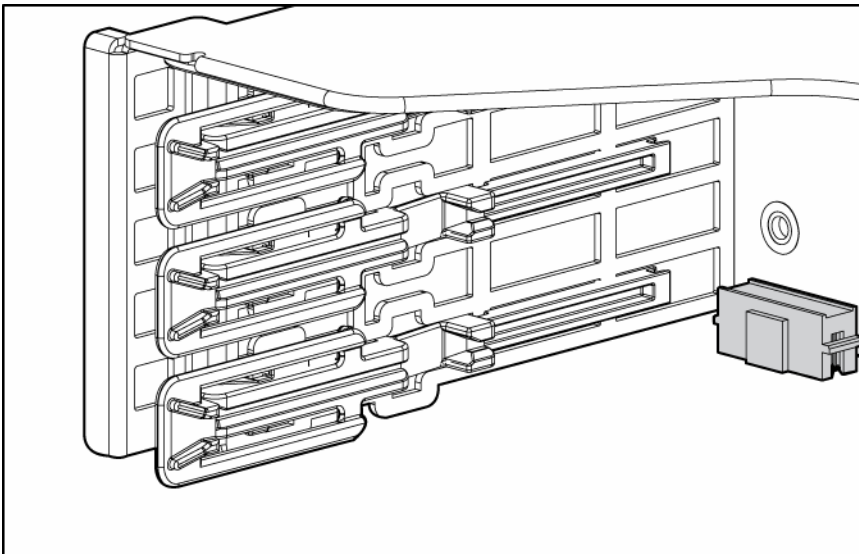

## Internal PCI Hot Plug LEDs and button

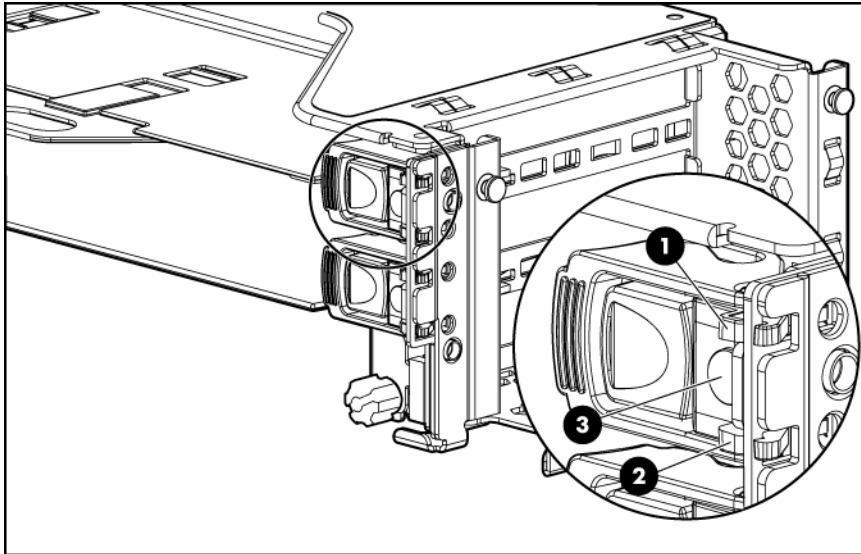

 **NOTE:** Hot-plug LEDs are available only with the optional hot-plug PCI riser cage.

Item	Description	Status
1	Fault LED (Amber)	On = Expansion board failed. Off = Normal
2	Power LED (Green)	On = Power is applied to the slot. Flashing = Power is cycling. Off = Power is not applied to the slot.
3	PCI Hot Plug button	N/A

## Identifying hot-plug fans

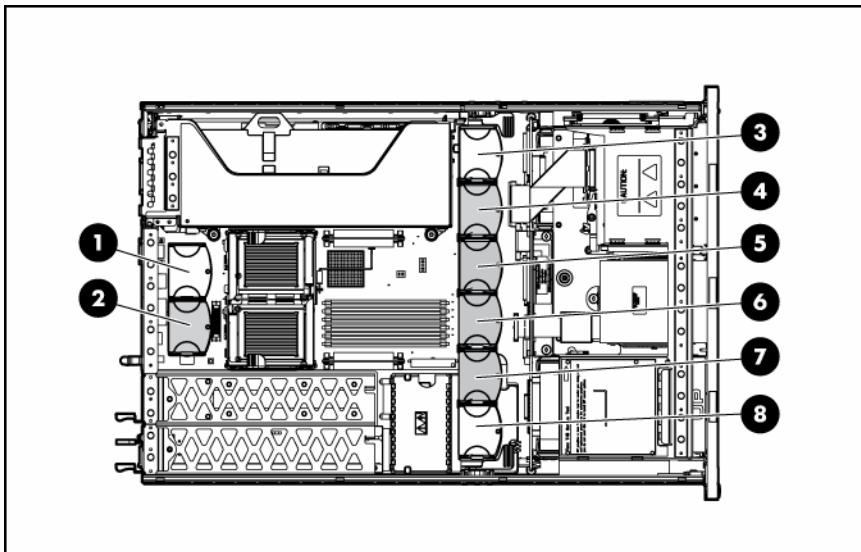

Item	Description	Configuration
1	Fan 1	Redundant

Item	Description	Configuration
2	Fan 2	Primary
3	Fan 3	Redundant
4	Fan 4	Primary
5	Fan 5	Primary
6	Fan 6	Primary
7	Fan 7	Primary
8	Fan 8	Redundant

## Hot-plug fan LED

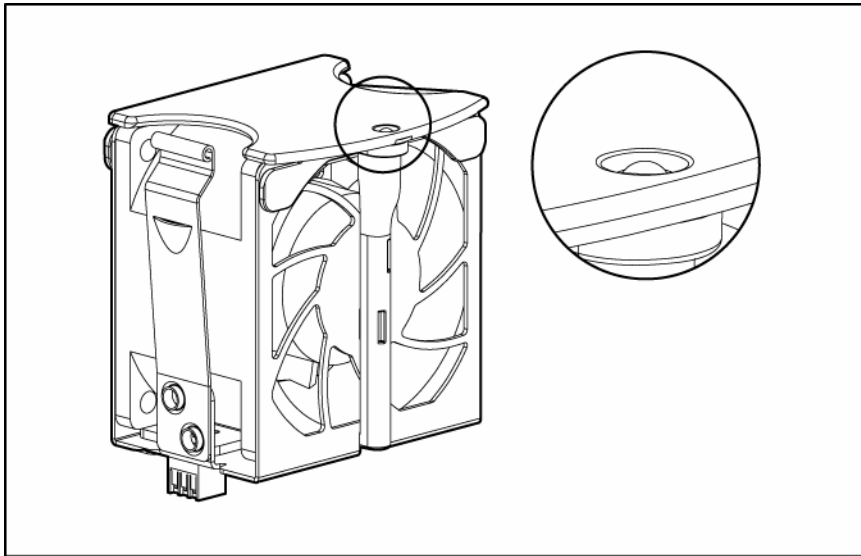

Status
Green = Operating normally
Amber = Failed
Off = No power

## Power converter module LED

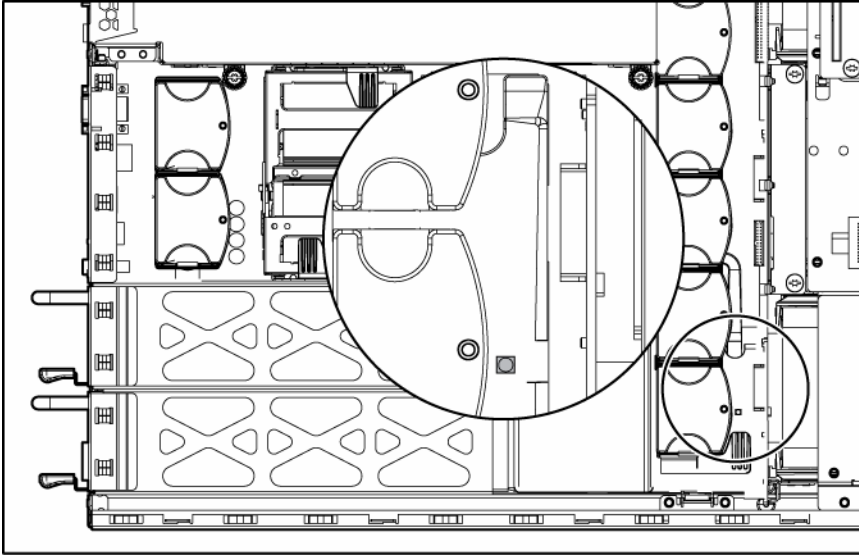

Status
Amber = Failed
Off = Operating normally

## Battery-backed write cache LEDs

 **NOTE:** This feature applies only to SCSI models.

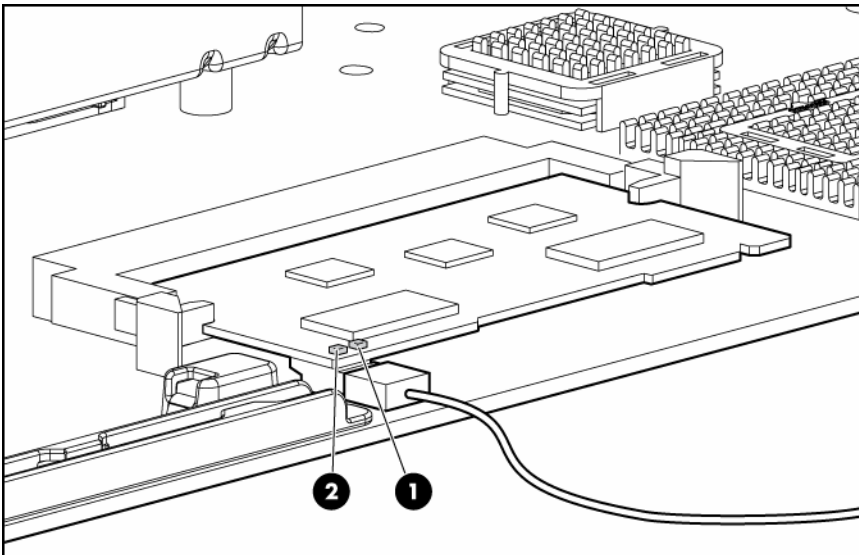

Item	LED color
1	Amber
2	Green

For LED status information, refer to "Battery-backed write cache LED statuses (on page 93)."

# Battery-backed write cache LED statuses



**NOTE:** This feature applies only to SCSI models.

Server status	LED status	Battery module status
Server is on and has normal run time	Green = On	Fast charging
	Green = Flashing	The microcontroller is waiting for communication from the host controller.
	Green = Off	The battery is fully charged.
	Amber = On	A short exists in the connection of one or more of the three button cells within the battery module.
	Amber = Flashing	An open exists in the circuit between the positive and negative terminals of the battery module.
	Amber = Off	Normal
Server is off and is in data retention mode	Amber = Flashing every 15 seconds	User data held in the write cache is being backed up.

# Specifications

## In this section

Server specifications .....	94
Environmental specifications .....	94
Hot-plug power supply calculations .....	95
DDR2 SDRAM DIMM specifications.....	95
1.44-MB diskette drive specifications.....	95
CD-ROM drive specifications .....	96
DVD-ROM drive specifications .....	97
Ultra320 SCSI hard drive specifications.....	98
SAS and SATA hard drive specifications.....	98

## Server specifications

Specification	Value
<b>Dimensions</b>	
Height	8.59 cm (3.38 in)
Depth	66.07 cm (26.01 in)
Width	44.54 cm (17.54 in)
Weight (maximum)	27.22 kg (60 lb)
Weight (no drives installed)	20.41 kg (47.18 lb)
<b>Input requirements</b>	
Rated input voltage	100 to 132 VAC, 200 to 240 VAC
Rated input frequency	50 Hz to 60 Hz
Rated input current	7.5 A (100 VAC), 3.8 A (200 VAC)
Rated input power	735 W
BTUs per hour	2508
<b>Power supply output</b>	
Rated steady-state power	575 W
Maximum peak power	575 W

## Environmental specifications

Specification	Value
<b>Temperature range*</b>	
Operating	10°C to 35°C (50°F to 95°F)

Specification	Value
Shipping	-30°C to 50°C (-22°F to 122°F)
Storage	-40°C to 70°C (-40°F to 158°F)
Maximum wet bulb temperature	28°C (82.4°F)
<b>Relative humidity (noncondensing)**</b>	
Operating	10% to 90%
Non-operating	5% to 95%

\* All temperature ratings shown are for sea level. An altitude derating of 1°C per 300 m (1.8°F per 1,000 ft) to 3048 m (10,000 ft) is applicable. No direct sunlight allowed.

\*\* Storage maximum humidity of 95% is based on a maximum temperature of 45°C (113°F). Altitude maximum for storage corresponds to a pressure minimum of 70 KPa.

## Hot-plug power supply calculations

For hot-plug power supply specifications and calculators to determine electrical and heat loading for the server, refer to the HP Enterprise Configurator website (<http://h30099.www3.hp.com/configurator/>).

## DDR2 SDRAM DIMM specifications

**△ CAUTION:** Be sure to install DIMMs in the proper configuration. Refer to the Documentation CD.

Item	Description
Size	512 MB, 1 GB, 2 GB
Width	72 bits
Upgrade requirement *	Any combination of like-paired DDR2 DIMMs that provide a minimum of 512 MB

\*Use only 512-MB, 1-GB, or 2-GB, 72-bit wide, 1.8-V, PC2-3200 Registered ECC DDR2. Use HP DDR2 only.

## 1.44-MB diskette drive specifications

Specification	Value
<b>Dimensions</b>	
Height	12.7 mm (0.5 in)
Width	96 mm (3.8 in)
Depth	130 mm (5.1 in)
LEDs (front panel)	Green = On
<b>Read/write capacity per diskette</b>	
High density	1.44 MB
Low density	720 KB
Drives supported	1
Drive height	One-third height
Drive rotation	300 rpm
<b>Transfer rate</b>	

Specification	Value
High	500 Kb/s
Low	250 Kb/s
Bytes/sector	512
Sectors per track (high/low)	18/9
Tracks per side (high/low)	80/80
<b>Access times</b>	
Track-to-track (high/low)	3 ms/6 ms
Average (high/low)	169 ms/94 ms
Setting time	15 ms
Latency average	100 ms
Cylinders (high/low)	80/80
Read/write heads	2

## CD-ROM drive specifications

Specification	Value
Disk formats	CD-ROM (modes 1 and 2); mixed mode (audio and data combined); CD-DA; Photo CD (single/multiple-session), CD-XA ready; CDi ready
Capacity	550 MB (mode 1, 12 cm)
	640 MB (mode 2, 12 cm)
Block size	2368, 2352 bytes (mode 0)
	2352, 2340, 2336, 2048 bytes (mode 1)
	2352, 2340, 2336, 2048 bytes (mode 2)
<b>Dimensions</b>	
Height	12.7 mm (0.50 in)
Depth	132.08 mm (5.20 in)
Width	132.08 mm (5.20 in)
Weight	0.34 kg (0.75 lb)
<b>Data transfer rate</b>	
Sustained	150 KB/s (sustained 1X), 1500/3600 KB/s (10X to 24X)
Burst	16.6 MB/s
<b>Access times (typical)</b>	
Full stroke	300 ms
Random	140 ms
Diameter	12 cm, 8 cm (4.70 in, 3.15 in)
Thickness	1.2 mm (0.05 in)
Track pitch	1.6 $\mu\text{m}$ ( $6.3 \times 10^{-7}$ in)
Cache/buffer	128 KB
Startup time	< 10 s
Stop time	< 5 s (single); < 30 s (multisession)



Specification	Value
<b>Laser parameters</b>	
Type	Semiconductor laser GaAs
Wave length	700 ± 25 nm
Divergence angle	53.5° ± 1.5°
Output power	0.14 mW
<b>Operating conditions</b>	
Temperature	5°C to 45°C (41°F to 118°F)
Humidity	5% to 90%

## DVD-ROM drive specifications

Specification	Value
Disk formats	DVD (single and double layer), DVD-5, DVD-9, DVD-10, DVD-R, CD-ROM Mode 1 & 2, CD-DA, CD-XA (Mode 2, Form 1 & 2), CD-I (Mode 2, Form 1 & 2), CD-I ready, CD-Bridge, CD-R, PhotoCD (single and multi-session)
Capacity	4.7 GB (DVD-5), 8.5 GB (DVD-9), 9.4 GB (DVD10), 550 Mb (Mode 1, 12 cm), 640 Mb (Mode 2, 12 cm), 180 Mb (8 cm)
Block size	2352 bytes (mode 0) 2352, 2340, 2336, 2048 bytes (mode 1) 2352, 2340, 2336, 2048 bytes (mode 2) 2048 bytes (DVD)
<b>Dimensions</b>	
Height	12.7 mm (0.50 in)
Depth	132.08 mm (5.20 in)
Width	132.08 mm (5.20 in)
Weight	0.34 kg (0.75 lb)
<b>Data transfer rate</b>	
Sustained	4463 - 10,800 KB/s (8X CAV DVD mode), 150 KB/s (sustained 1X CD-ROM), 1552 3600 KB/s (24X CAV CD-ROM)
Burst	16.6 MB/s with DMA support
<b>Access times (typical)</b>	
Full stroke	<200 ms CD <300 ms DVD
Random	<110 ms CD <180 ms DVD
Diameter	12 cm, 8 cm (4.70 in, 3.15 in)
Thickness	1.2 mm (0.05 in)
Track pitch	0.74 μm (3.15 × 10 <sup>-7</sup> in) DVD-ROM 1.6 μm (6.3 × 10 <sup>-7</sup> in) CD-ROM
Cache/buffer	128 KB
Startup time	< 10 s
Stop time	< 5 s (single); < 30 s (multisession)

Specification	Value
<b>Laser parameters</b>	
Type	Semiconductor laser GaAs
Wave length	700 ± 25 nm
Divergence angle	53.5° ± 1.5°
Output power	0.14 mW
<b>Operating conditions</b>	
Temperature	5°C to 45°C (41°F to 118°F)
Humidity	5% to 90%

## Ultra320 SCSI hard drive specifications

Item	36.4-GB Ultra320 SCSI drive	72.8-GB Ultra320 SCSI drive	72.8-GB Ultra320 SCSI drive	146.8-GB Ultra320 SCSI drive
Capacity	36,419.6 MB	72,837.2 MB	72,837.2 MB	146,815.74 MB
Height	1.0 in (One-third height)	1.0 in (One-third height)	1.0 in (One-third height)	One-third, 1.0 in
Width	4.0 in	4.0 in	4.0 in	4.0 in
Interface	Ultra320 SCSI	Ultra320 SCSI	Ultra320 SCSI	Ultra320SCSI
Transfer rate	320 MB/sec	320 MB/sec	320 MB/sec	320 MB/sec
Rotational speed	15,000 rpm	10,000 rpm	15,000 rpm	10,000 rpm
Bytes per sector	512	512	512	512
Logical blocks	71,132,000	142,264,000	142,264,000	286,749,488
Operating temperature	10°C to 35°C (50°F to 95°F)	10°C to 35°C (50°F to 95°F)	10°C to 35°C (50°F to 95°F)	10°C to 35°C (50°F to 95°F)

## SAS and SATA hard drive specifications

Item	36-GB SAS drive	72-GB SAS drive	60-GB SATA drive
Capacity	36,420 MB	73,408 MB	60,022 MB
Height	15 mm	15 mm	9 mm
Interface	SAS	SAS	Serial ATA
Transfer rate	3 GB/sec	3 GB/sec	1.5 GB/sec
Rotational speed	10,000 rpm	10,000 rpm	5,400 rpm
Bytes per sector	512	512	512
Logical blocks	71,132,960	143,374,737	117,231,408
Operating temperature	10°C to 35°C (50°F to 95°F)	10°C to 35°C (50°F to 95°F)	10°C to 35°C (50°F to 95°F)

---

# Acronyms and abbreviations

## ABEND

abnormal end

## ASR

Automatic Server Recovery

## BBWC

battery-backed write cache

## BIOS

Basic Input/Output System

## DDR

double data rate

## DIMM

dual inline memory module

## IDE

integrated device electronics

## iLO

Integrated Lights-Out

## IML

Integrated Management Log

## LED

light-emitting diode

## NMI

non-maskable interrupt

## NVRAM

non-volatile memory

## ORCA

Option ROM Configuration for Arrays

## PCI

peripheral component interface

## PCI Express

peripheral component interconnect express

## PCI-X

peripheral component interconnect extended

## POST

Power-On Self Test

## PPM

processor power module

## RBSU

ROM-Based Setup Utility

## RDP

Remote Desktop Protocol

## RILOE II

Remote Insight Lights-Out Edition II

## SAS

serial attached SCSI

## SATA

serial ATA

## SCSI

small computer system interface

## SDRAM

synchronous dynamic RAM

## SNMP

Simple Network Management Protocol

UID

unit identification

USB

universal serial bus

VHDCI

very high density cable interconnect

---

# Index

## A

AC power supply 78  
ADU (Array Diagnostic Utility) 69  
Altiris Deployment Solution 71  
Altiris eXpress Deployment Server 71  
Array Diagnostic Utility (ADU) 69  
ASR (Automatic Server Recovery) 69, 99  
Automatic Server Recovery (ASR) 69, 99  
Autorun menu 72

## B

battery 41, 80  
BIOS upgrade 72  
blue screen event 80  
buttons 74, 76, 78, 90

## C

cables 54  
cabling 54, 56, 57, 58, 59, 60, 61, 63, 64, 65, 66, 67  
cautions 17  
CD ejector assembly 23  
CD-ROM drive 22, 23, 56, 96  
chassis ID switch 80  
component identification 74, 80, 85, 87  
components 74  
components, mechanical 7, 12  
components, system 8, 13  
connectors 74  
crash dump analysis 80  
creating a disk image 71  
CSR (customer self repair) 6  
customer self repair (CSR) 6

## D

DC power supply 78  
deployment software 71  
diagnostic tools 69, 70, 71, 72  
diagnostics utility 70  
DIMM slot LEDs 82, 85  
DIMM slots 80

DIMMs 38, 95  
diskette drive 24, 65, 95  
diskette drive connectors 82  
diskette image creation 71  
drive LEDs 85, 86  
duplex SCSI hard drive configuration 59  
DVD-ROM drive 22, 97  
DVD-ROM drive connectors 82

## E

electrostatic discharge 17  
expansion slot covers, removing 52  
expansion slot LEDs 78, 90  
extending server from rack 19  
external health LED 76

## F

fan brackets 25  
fan connectors 79  
fan LED 82, 85, 91  
fan zones 86  
fans 90, 91  
features 74  
flash ROM 72  
front panel buttons 76  
front panel LEDs 76, 87

## H

hard drive blanks 44, 46  
hard drive LEDs 85, 86, 87  
hard drives 44, 85, 86, 87, 98  
hard drives, determining status of 85, 86  
health driver 69, 85  
health LEDs 76, 80, 85  
HP Insight Diagnostics 17, 70  
HP ProLiant Essentials Foundation Pack 71  
HP ProLiant Essentials Rapid Deployment Pack 71  
HP Systems Insight Manager, overview 71

## I

illustrated parts catalog 6  
iLO (Integrated Lights-Out) 71, 99

iLO connector 77  
IML (Integrated Management Log) 70  
Insight Diagnostics 70  
Integrated Lights-Out (iLO) 71, 99  
Integrated Management Log (IML) 70  
internal health LED 76, 83

## K

keyboard connector 77

## L

LEDs 74  
LEDs, hard drive 85, 86, 87

## M

management tools 69  
mechanical components 7, 12  
memory 38  
memory dump 80  
memory slot LEDs 82  
memory slots 80  
mouse connector 77

## N

network connector LEDs 78  
NIC connectors 77, 87  
NIC LEDs 76  
NMI switch 80

## O

Online ROM Flash Component Utility 73  
online spare memory LED 82  
operating system crash 80  
Option ROM Configuration for Arrays (ORCA) 71  
ORCA (Option ROM Configuration for Arrays) 71  
overtemperature LED 82, 86

## P

part numbers 6  
PCI array controllers, cabling 60, 61  
PCI Hot Plug backplane cabling 57  
PCI Hot Plug LEDs 78, 90  
PCI riser cage 30, 89  
PCI riser cage connector 79  
power button cabling 66  
power button/LED system connector 82  
power connectors, internal 82  
power converter module LED 92

power cord connector 77  
power LEDs, system 76  
Power On/Standby button 66, 76  
power requirements 95  
power supplies 78, 95  
power supply blank 48  
power supply LEDs 78, 92  
power supply signal connector 79  
PPM failure LEDs 82, 86  
PPM slots 79  
preparation procedures 18  
processor failure LEDs 82  
processors 79

## R

RBSU (ROM-Based Setup Utility) 72, See ROM-Based Setup Utility (RBSU)  
rear components 77  
rear panel buttons 78  
rear panel LEDs 78  
Remote Insight Lights-Out Edition board 58, 89  
remote management connector 89  
removal and replacement procedures 17  
removing server from rack 20  
required tools 17  
resetting the system 80  
RILOE II (Remote Insight Lights-Out Edition II) 58, 60, 89  
riser interlock LED 82  
RJ-45 network connector LEDs 78  
ROM, updating 73  
ROMPaq utility 72

## S

safety considerations 17  
SAS backplane 82  
SAS backplane components 82  
SAS connector 82  
SAS hard drive LEDs 87  
SCSI backplane components 81  
SCSI backplane LEDs 85  
SCSI cabling 58  
SCSI connectors 82  
SCSI terminator 63  
serial connector 77  
serial number 43  
server, front panel LEDs 76  
server, rear panel LEDs 78  
simplex SCSI hard drive configuration 60  
SmartStart autorun menu 72

- SmartStart, overview 72
- specifications 94, 95, 96, 97
- specifications, environmental 94
- specifications, server 94, 95, 98
- static electricity 17
- Survey Utility 70
- system board components 77
- system board LEDs 82, 83
- system components 8, 13
- system maintenance switch 77, 79, 80
- system power LED 76
- Systems Insight Manager 71

## **T**

- telco racks 18, 20
- temperature, overtemperature LED 82, 86
- troubleshooting 69

## **U**

- UID LEDs 74, 76, 78
- USB connectors 64, 87
- USB devices 64
- utilities, deployment 71, 72

## **V**

- VHDCI SCSI connector 77
- video connector 77

## **W**

- warnings 17